

Efficiency Days - 2010 HMI Hannover

SIEMENS



Condition Based Monitoring as part of Asset Management, Condition Management and Energy Efficiency in order to improve Plant and Production Optimization.

- **New Trends in Prozess Automation**
- **Asset Management**
- **Condition Management**
- **Energy Efficiency**

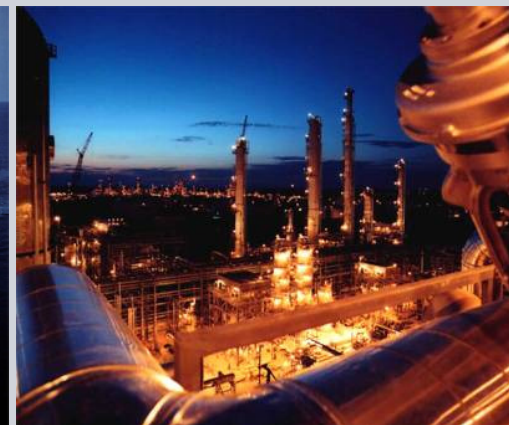

Production Efficiency

**Process Optimization with intelligent Analytics and Instrumentation
Solutions with advanced Diagnostic functionalities in order to improve
Plant / Energy Efficiency**



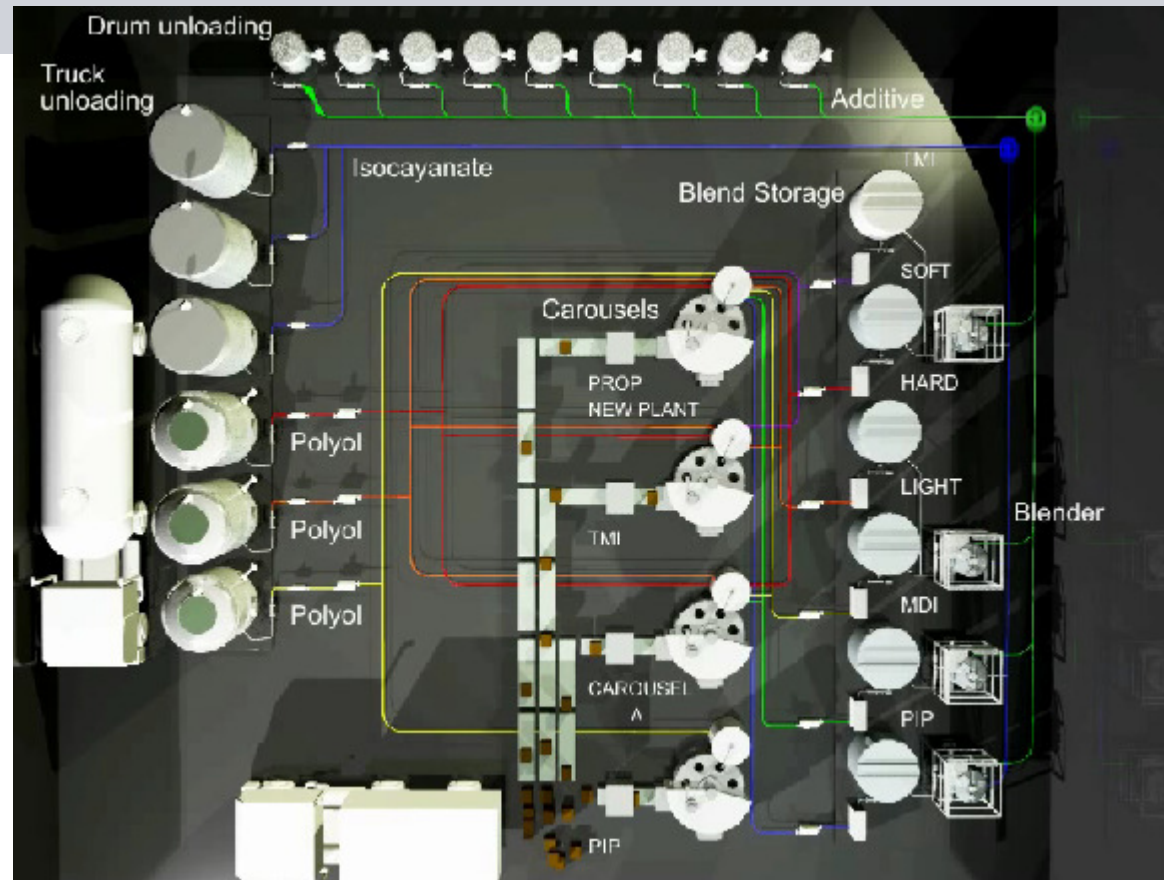

Reduction of unscheduled downtime, protection of equipment, improvements on safety and reduction on preventive maintenance

Unique Portfolio or Hybrid Industries

SIEMENS

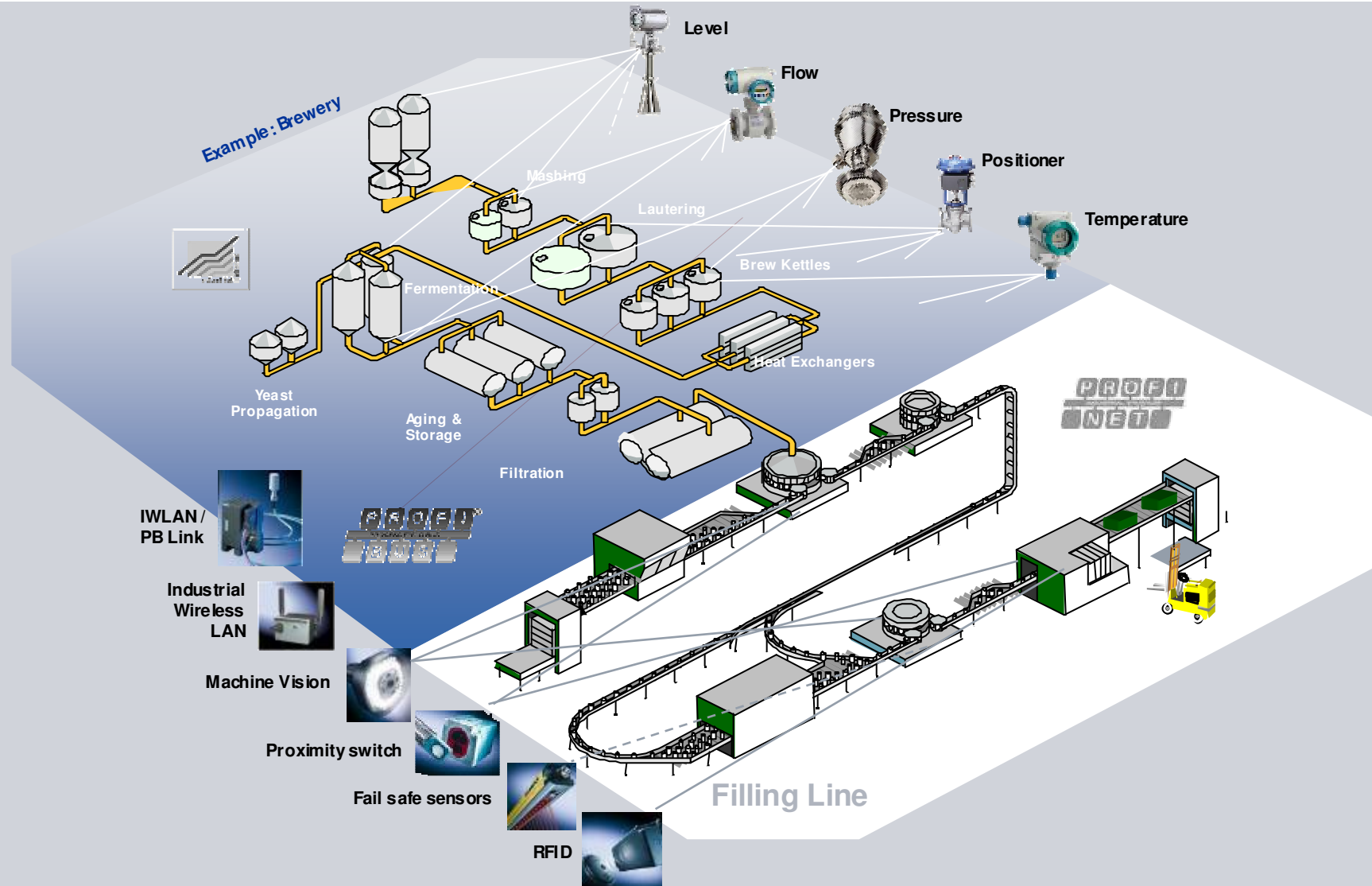

SIEMENS

Sensors & Communication

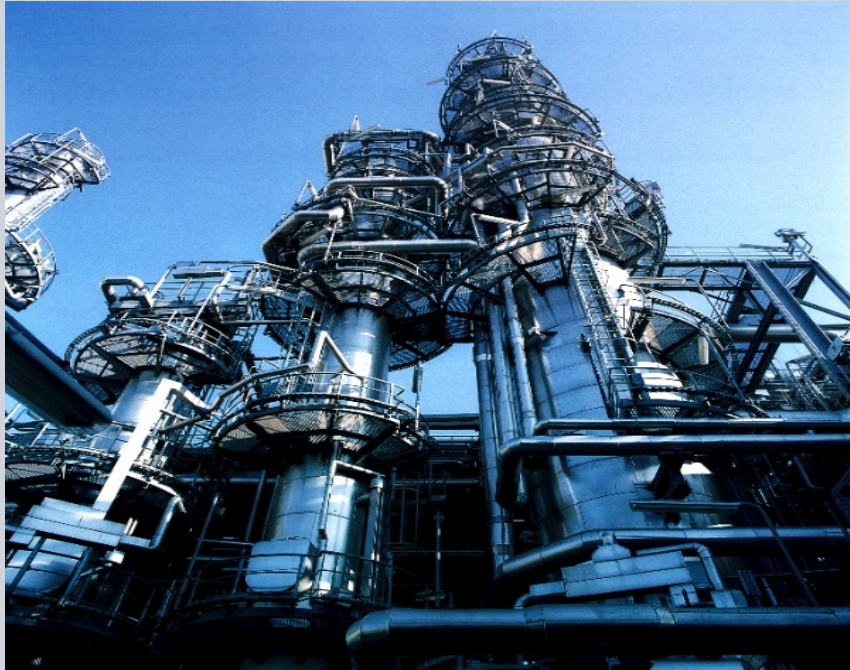

Industry Competence and Tools

Chem / Petrochem and Oil&Gas Industry

Topics Keyboard Chem/Petrochem and Oil&Gas Industry



SIEMENS Customized Presentation	Market Analysis	Segmentation Up/Downstream	Segmentation Chem/Petroch
Segmentation Oil&Gas	Total Cost of Ownership	Energy Efficiency	Asset Managem. Condition Mgmt. Diagnostics
Training	Documents	Company References	Competitor Analysis
Technology Keyboard	Product Portfolio	Product Selector	Product Fit Analysis
Key Customers	Vendor Listing Prequalificat.	Country Activities	Wireless Sensors/Com.
Safety SIL,EEx,Profis.	Quality/Cert. 3.1 / 3.2	MarketingComm.	Solutions
Operational Conditions	Innovation	Application Keyboard	Fiscal Metering Custody Transf.

Toluene Loading Station

Condition based Monitoring and Process Optimization using Process Automation and Analytic Technologies with intelligent Diagnostics and Monitoring Functionalities



From Condition based Monitoring to Condition Management

SIEMENS

Condition based Monitoring / Management is a major process in order to optimize production processes concerning facility operation, efficiency , production quality, quantity and to achieve production repeatability particular during the running production process.

A major step is to identify the actual requirements, demands and future trends in various industries in all international regions, part of this process is the development and establishment of the competence concerning detailed segmentation of industries by total solutions, partial solutions as well as single components, applications and support.

In order to improve the achievement of business results, a reactive and preventive maintenance process of production facilities has to be turned into a predictive concept .

Selection Criterias / Requirement Specs

Physical Measurements
Technology-Selection

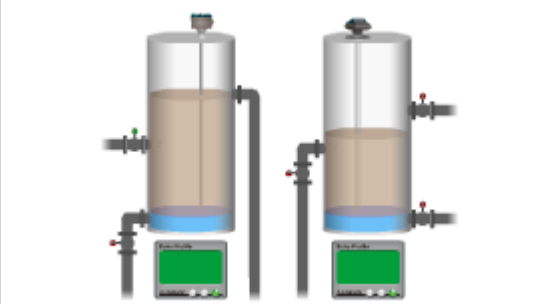

Industry-Segments Solutions



Application Database
Product-Selection Solutions

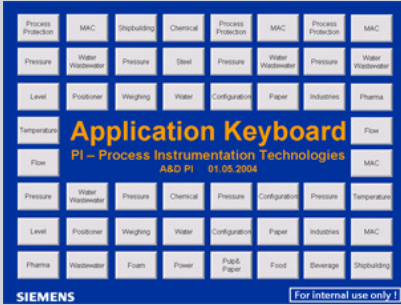

Chemical/Petrochem and Oil&Gas Industry Segmentation

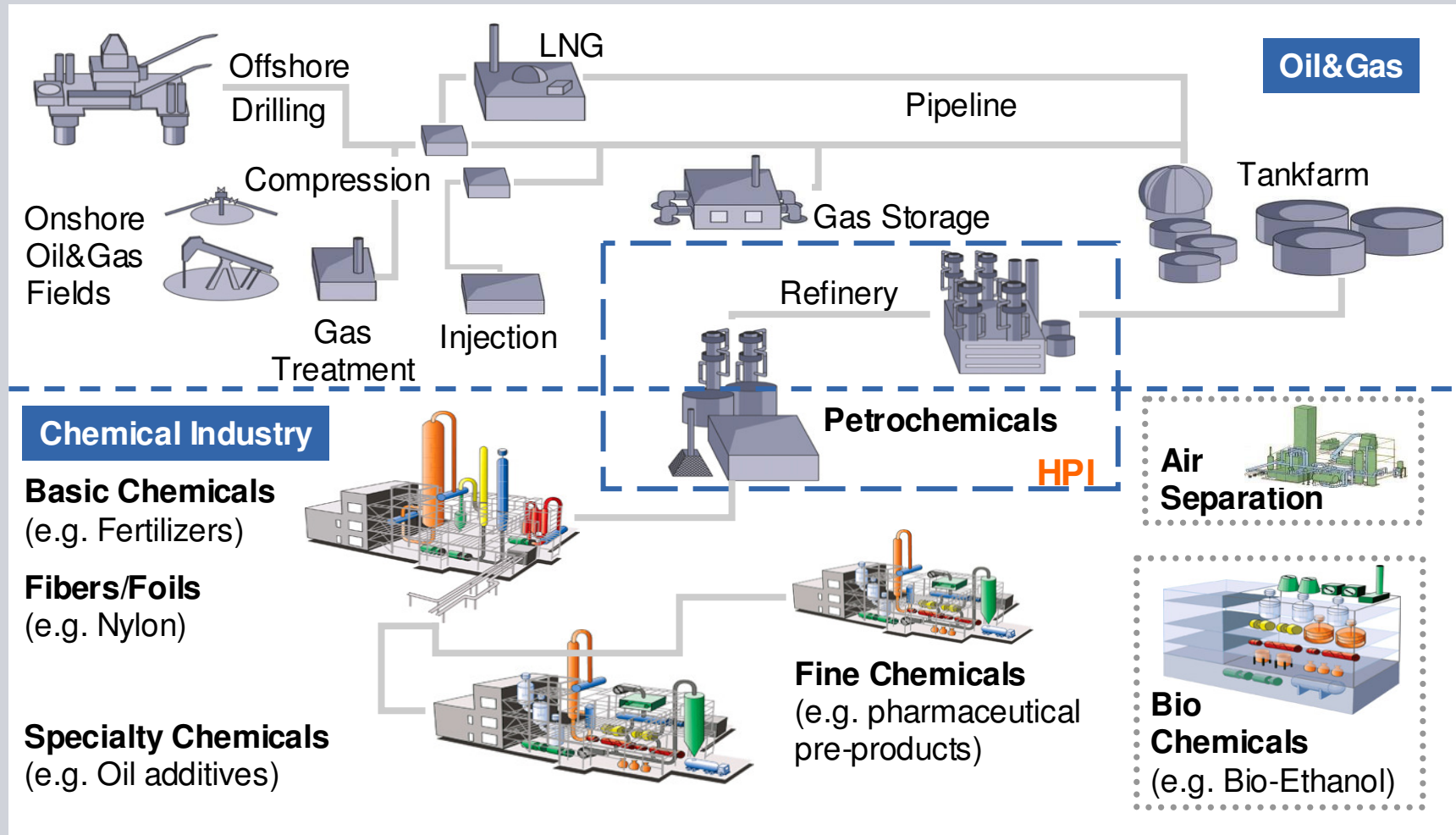

SIEMENS

Upstream - Offshore Exploration and Drill Rigs



Process Optimization on FPSOs

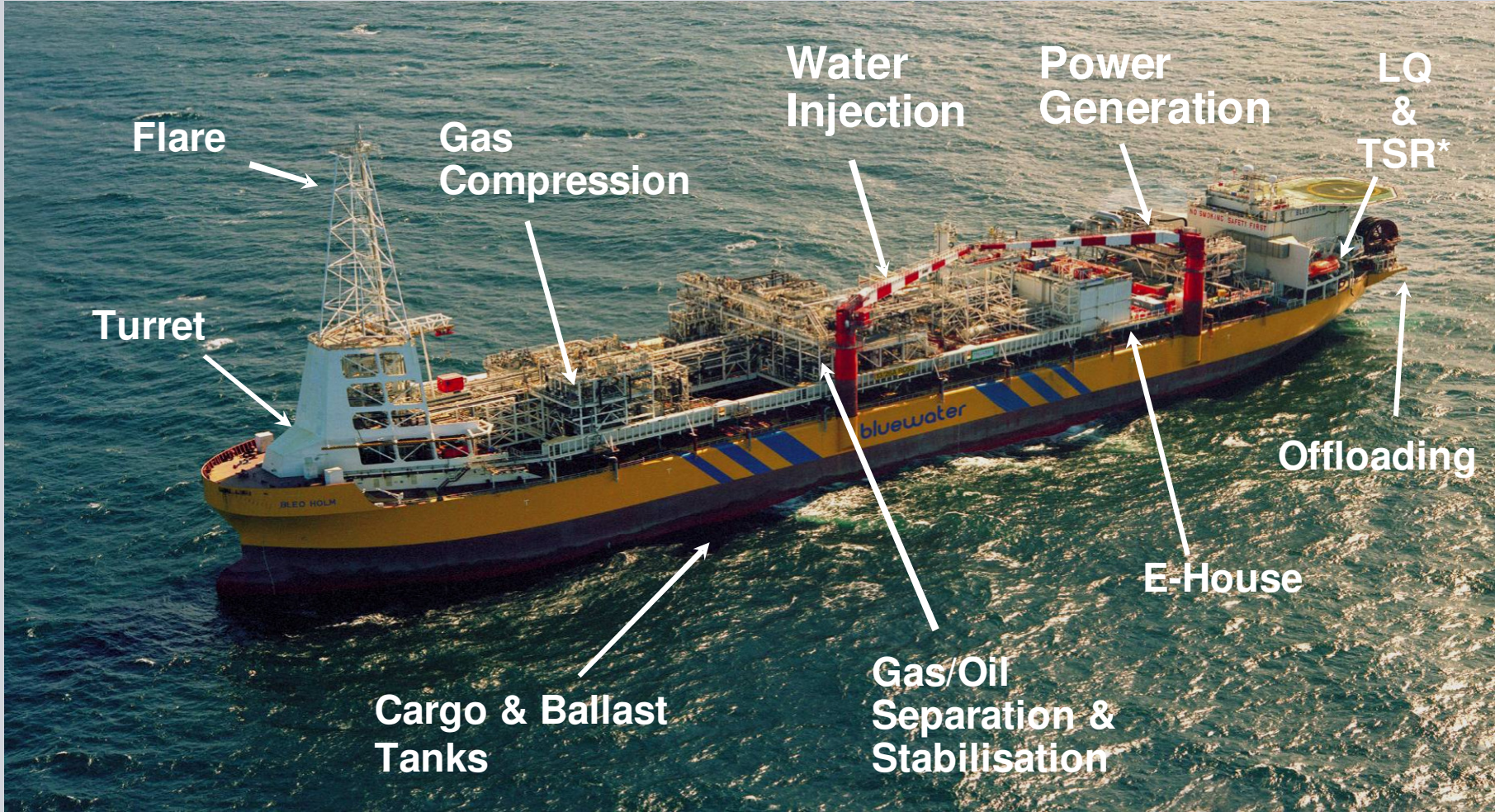

Total Breadth of Solutions for Oil & Gas Transportation - Pipelines and LNG/CNG Carriers



<p>IT Solutions</p> 	<p>Engineering, Project Management, Site Services</p> 	<p>Automation Systems, Process Instrumentation, Motors & Drives</p> 	<p>HVAC, Fire Protection, Security, Building Automation</p> 	<p>Maintenance & Service</p> 	<p>Power Transm. & Distribution, Energy Mgt.</p> 	<p>Power Gen., Compressors, Gas/Steam Turbines</p> 
---	---	---	---	--	--	--

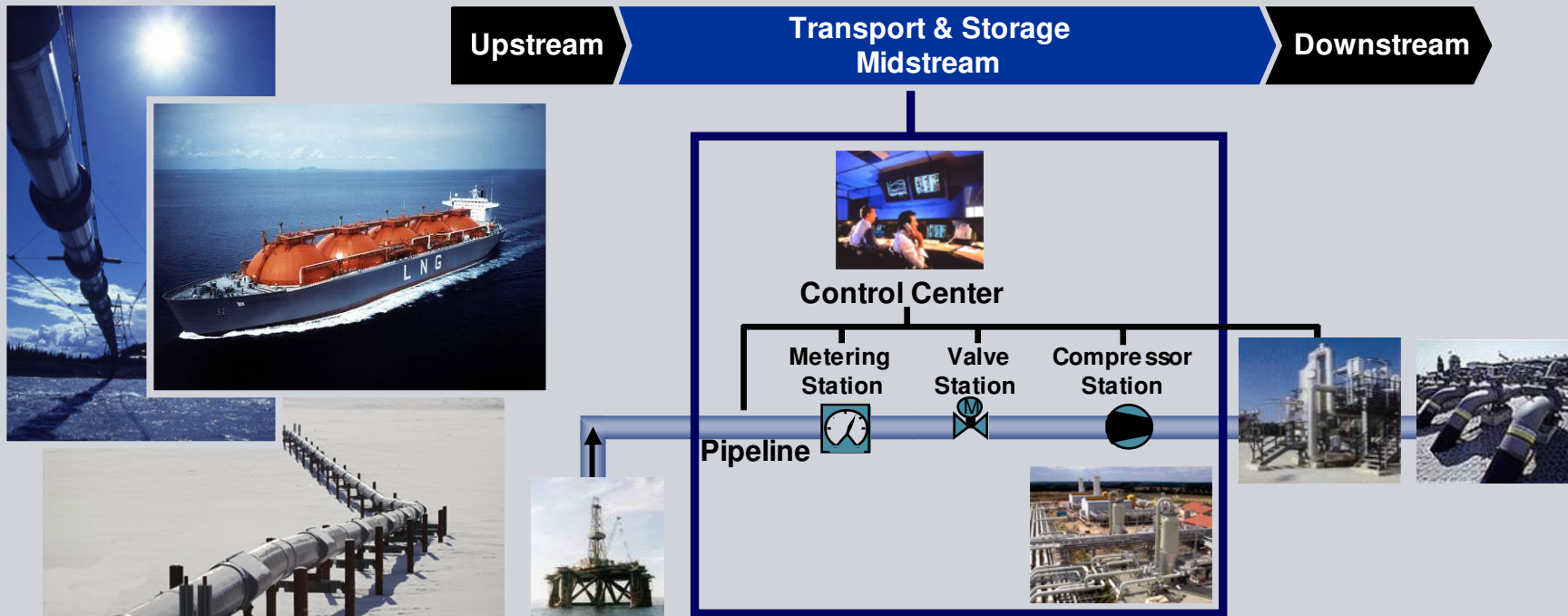

Leak Detection and Location

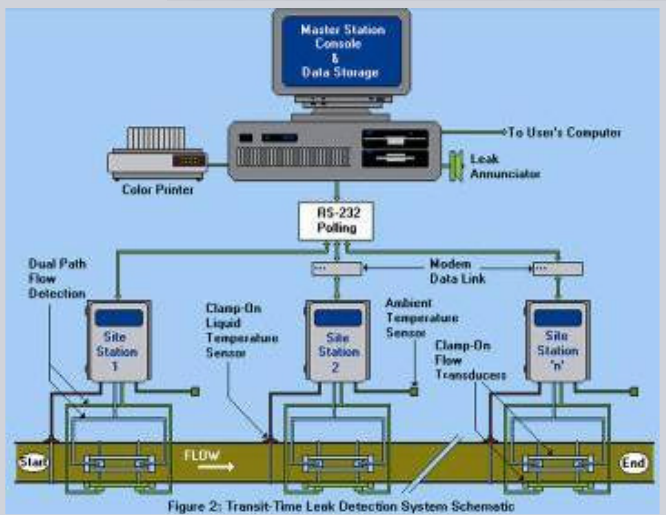

Storage - Tank Terminals



Safety shut down Systems



Ethanol tank farm on fire in Australia



Chemical tank farm accident



Barton Solvents tank farm fire in Kansas, 2007



Tank farm explosion near Dumas, Texas

Refineries

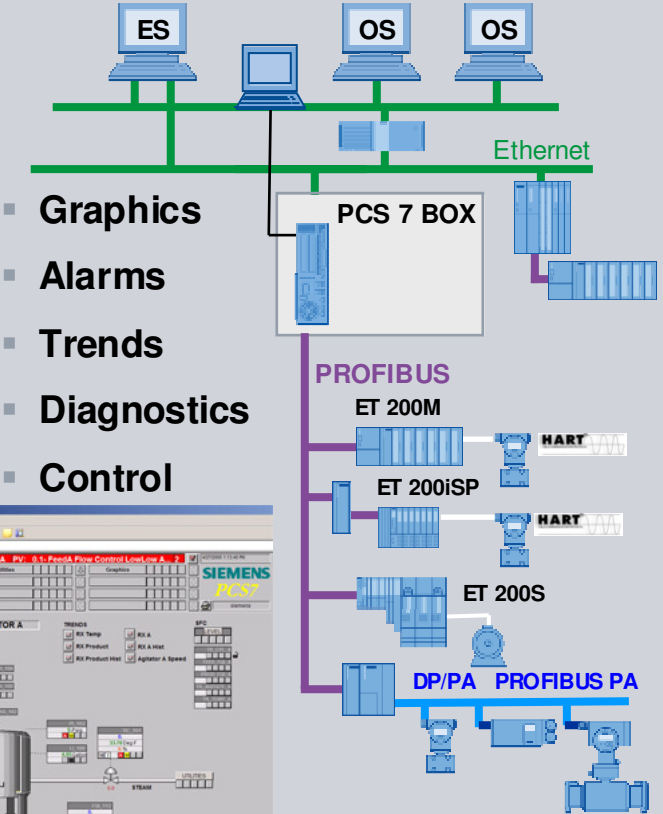
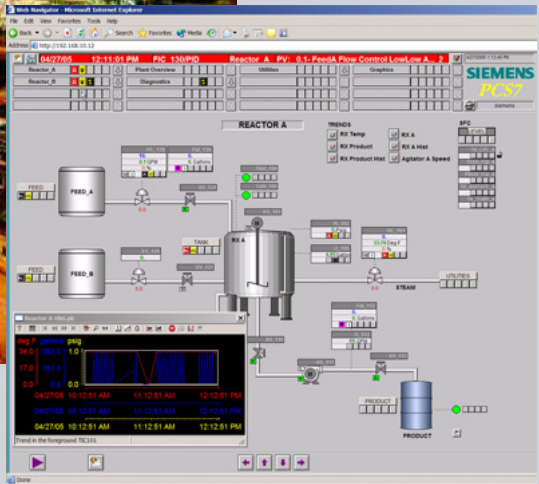

- Graphics
- Alarms
- Trends
- Diagnostics
- Control

**Process Instrumentation on Blending Utilization Processes
Level / Mass-Flow Measurement with LR 300 and LC 6000**

SIEMENS



Polyol and Additives Production Processes



Subsegment Process Reactors Polymer Production

SIEMENS



Condition Based Monitoring - ENERGY EFFICIENCY

- Asset and Condition Management
- Condition Monitoring and Process Optimization using Process Automation and Analytic Technologies with intelligent Diagnostics and Condition Based Monitoring
- Functionalities in order to improve Plant Efficiency / Energy Efficiency



Energy Efficiency

The topic of energy efficiency has come to dominate the field of industry. This is set to continue into the future as a result of political requirements and concern about the environment and climate.

The opportunity to gain cost and competitive advantages through the more efficient use of energy will also ensure that the topic does not lose its importance.

Although efforts have been made in the area of energy efficiency in the past, there is still significant room for improvement in the various industrial sectors.

Increase of Energy Efficiency with Process Automation Solutions



Contribution of process automation to improving energy efficiency

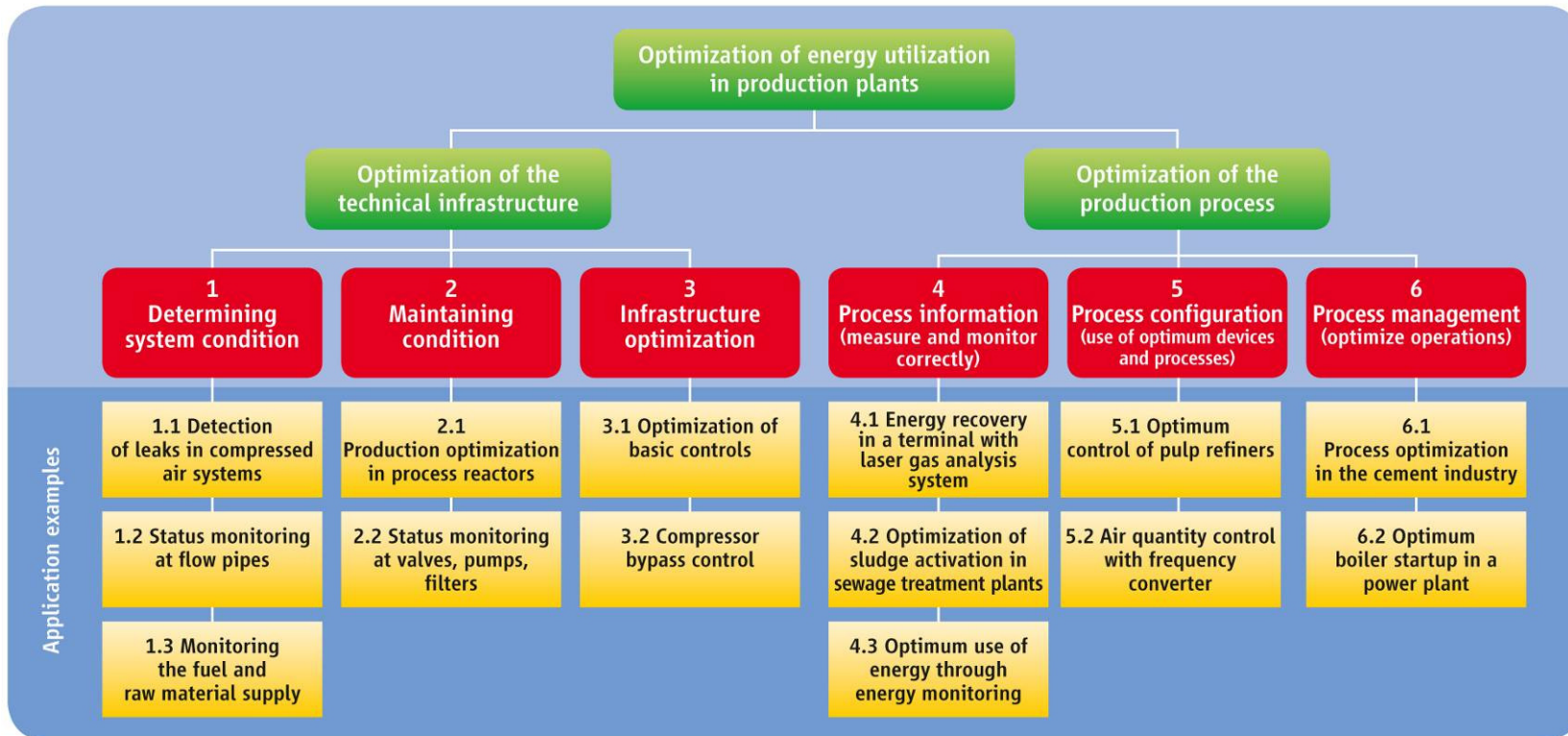

Source ZVEI

Energy Efficiency

Studies show that, from the energy source to the consumer, up to 80 % of the energy currently used in the various production, transmission and conversion stages can be lost.

Energy use today



Source ZVEI

Energy Efficiency

Process automation is central to energy efficiency and energy intelligence

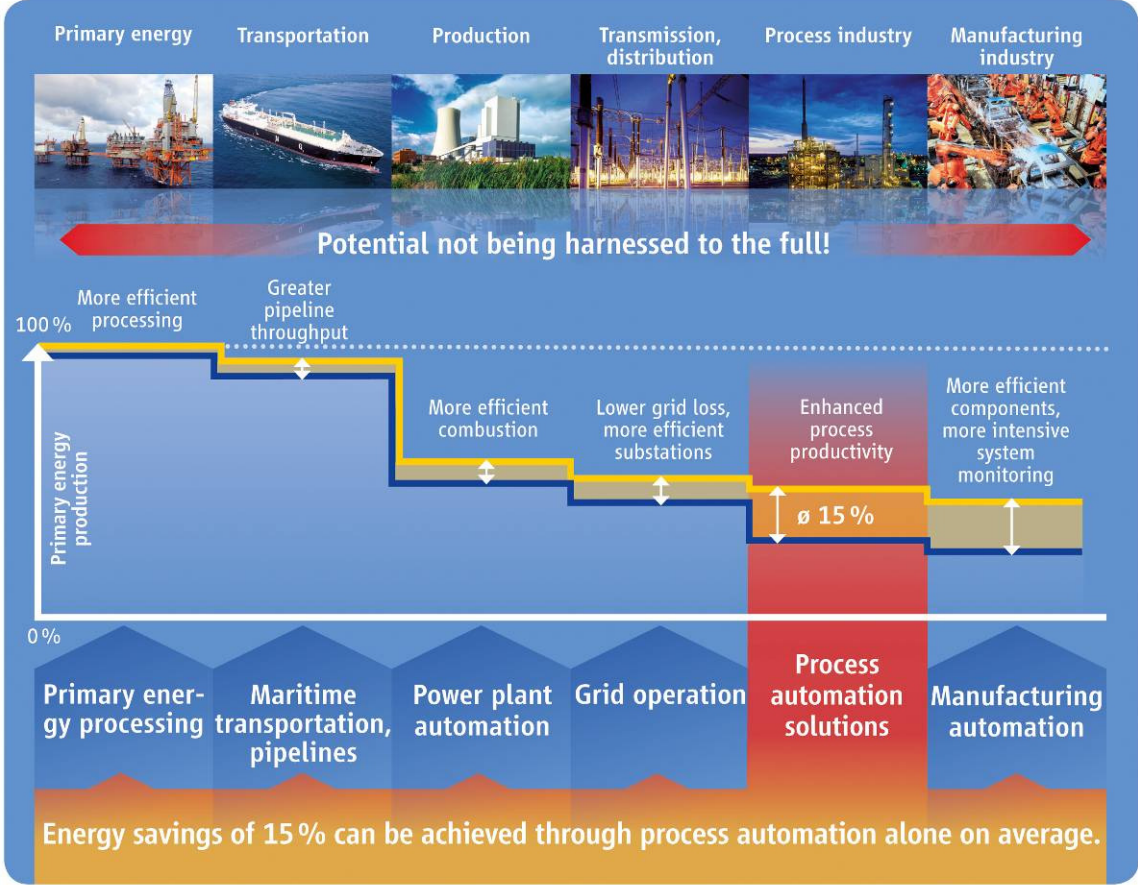

Source: ZVEI, ABB Group

Output without measures Output with measures

Source ZVEI

Major Market Trends in Process Automation

Goal:

Reduction of unscheduled down-time, protection of equipment, improvements on safety and reduction of maintenance.

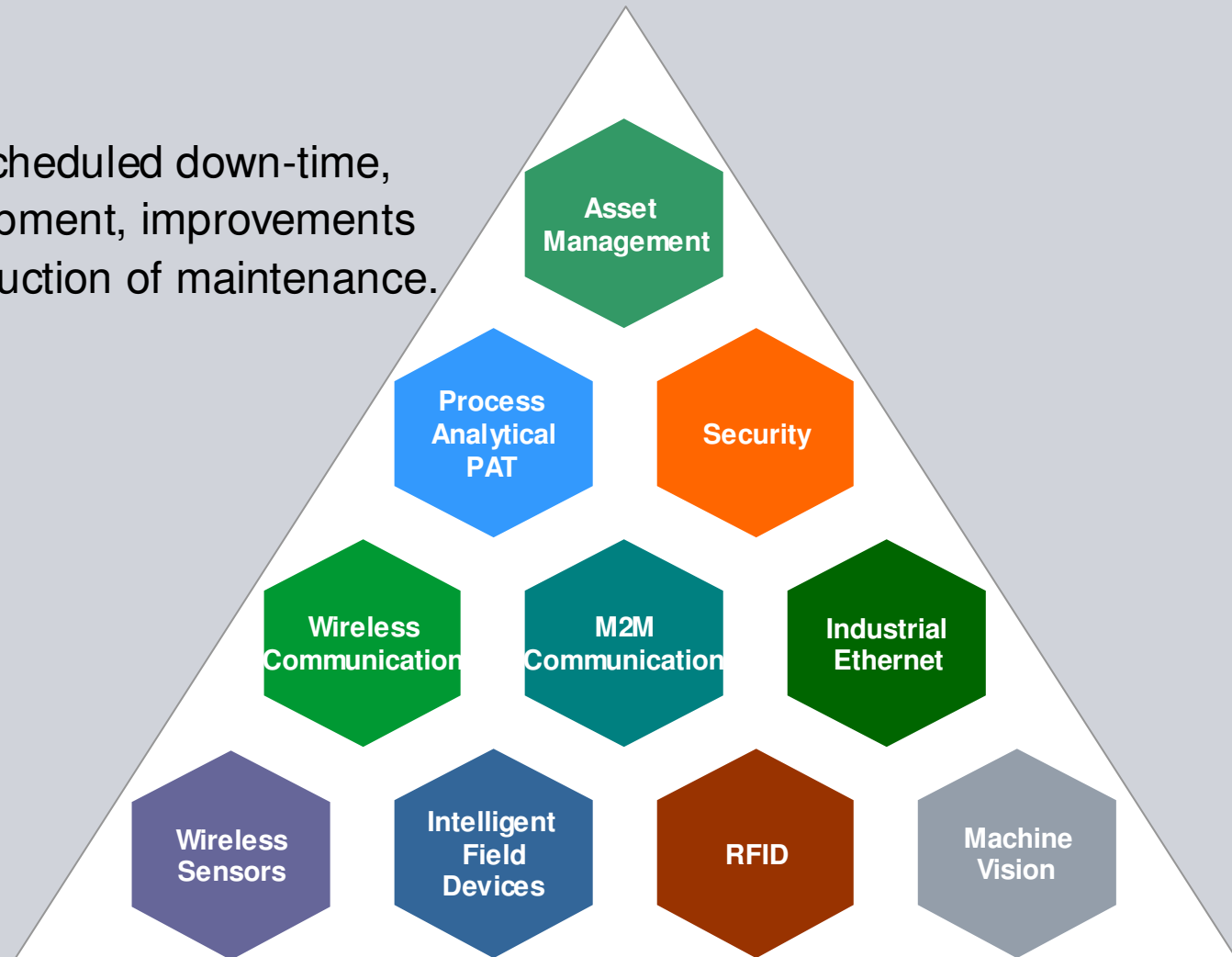

Definition of Plant Asset Management

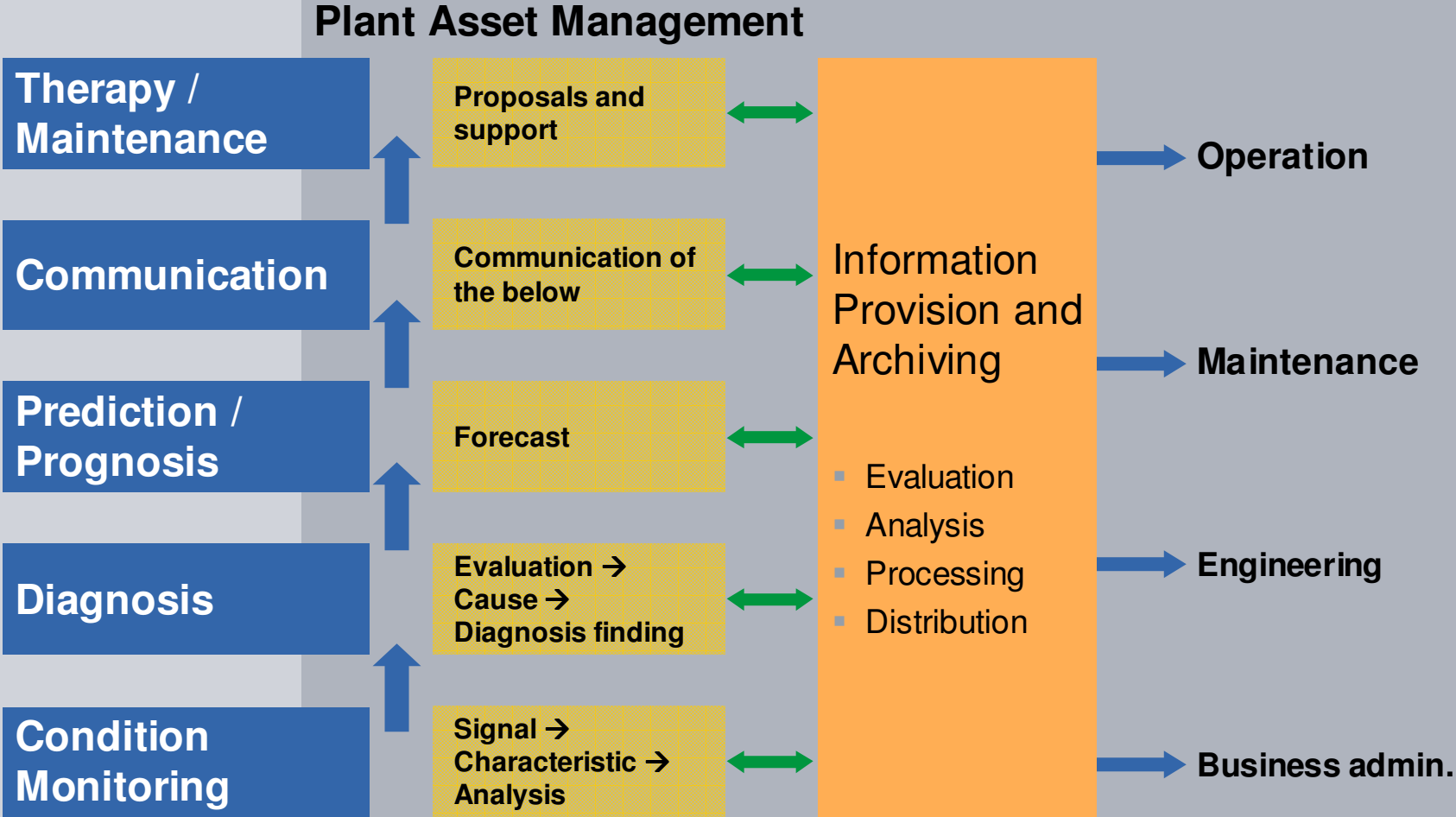

Totally Integrated Automation: Seamless Integration from Field to MES

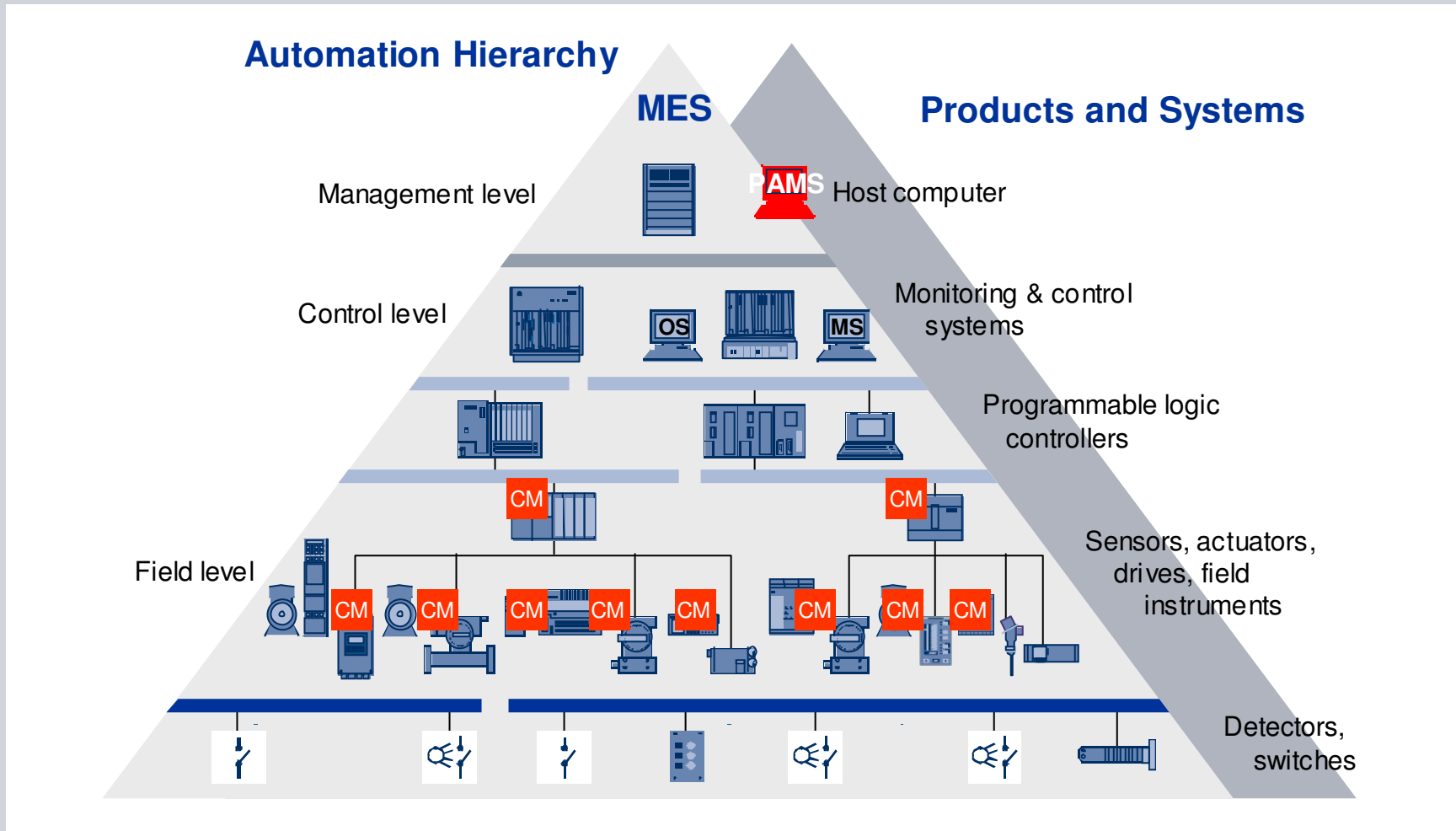

Integrated Plant Asset Management – Monitoring & Operating

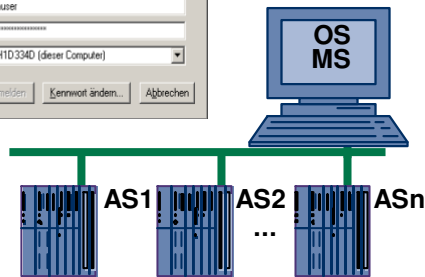
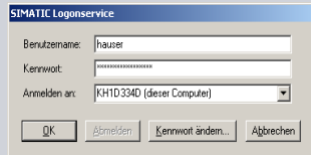

- Maintenance Station integrated into the Operator Station

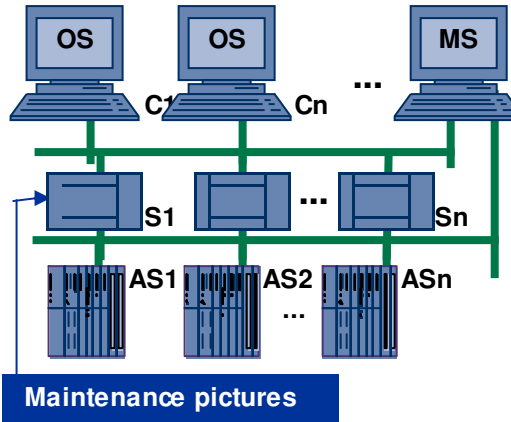

- OS Clients with access to maintenance area (pictures, messages, faceplates)
- Maintenance Station has additionally direct online access to PDM and hardware engineering

AS – Automation System
C – Client
MS – Maintenance Station
OS – Operator Station
S – Server

- All diagnostic capable SIMATIC PCS 7 components + „non-intelligent“ assets



- Common and unified symbols for representing the status of all assets

	Good		Announcement of request for maintenance (low)		Request for maintenance unknown/not activated
	Simulation		Request for maintenance (medium)		Request for maintenance activated
	Function control/ local		Maintenance alert (high)		Request for maintenance in process

Remote Monitoring Service – Tool for CBM Supported Products & Data Security

SIEMENS

Supported Products

- Compressors (STC)
- Steam Turbines (SST)
- Small Gas Turbines (SGT)
- Medium Gas Turbines (MGT)
- Generators and Motors

STA – RMS supports all products from
Energy Oil & Gas / Chem / Petrochem

Common Remote Service Platform ‘(cRSP)’

- Secure connection (VPN)
- Data Secure Zone (DSZ)
- Redundant „Fall Back“ concept
- Authentication and authorization concept
- CERT (Computer Emergency Response Team) und ISO 27001 certificated ‘

Guarantees the security of your data

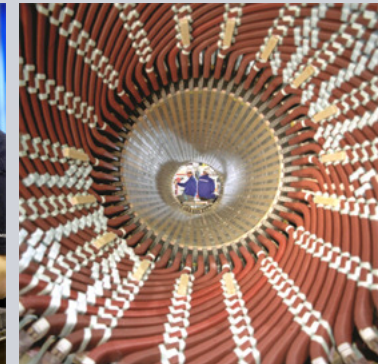
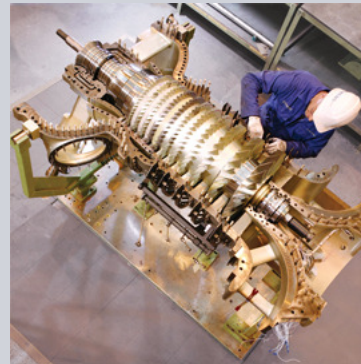

Life Cycle Management - Single Source for Services – **SIEMENS** Automation, Instrumentation, Electrical and Power

Introduction/ Situation	Requirements	Service Concept	Concept in detail	Benefits	Summary
		<p>Become a substantial part of the customer's operations team for entire scope of delivery</p>			
<p>Product Related Services</p> <ul style="list-style-type: none"> Keeping specialists – readiness for <ul style="list-style-type: none"> 24/7 hotline support and On-site fault elimination Software & Hardware updates Maintenance & uptime Services Includes third party equipment 		<p>Value Added Services</p> <ul style="list-style-type: none"> Remote assistance & diagnostics Condition based monitoring Modernisation & Migrations Shut Dows Services Consultation for Energy Saving, Project Management and Maintenance Process 		<p>Multi Vendor Services</p> <ul style="list-style-type: none"> Operation of the maintenance concept <ul style="list-style-type: none"> Planning Scheduling Performance Improving services focussed on Key Performance Indicators Reliability guarantees on demand 	

Life Cycle Management Concept Partner for the whole life-cycle of your plant



Capabilities for project development, Implementation and operation

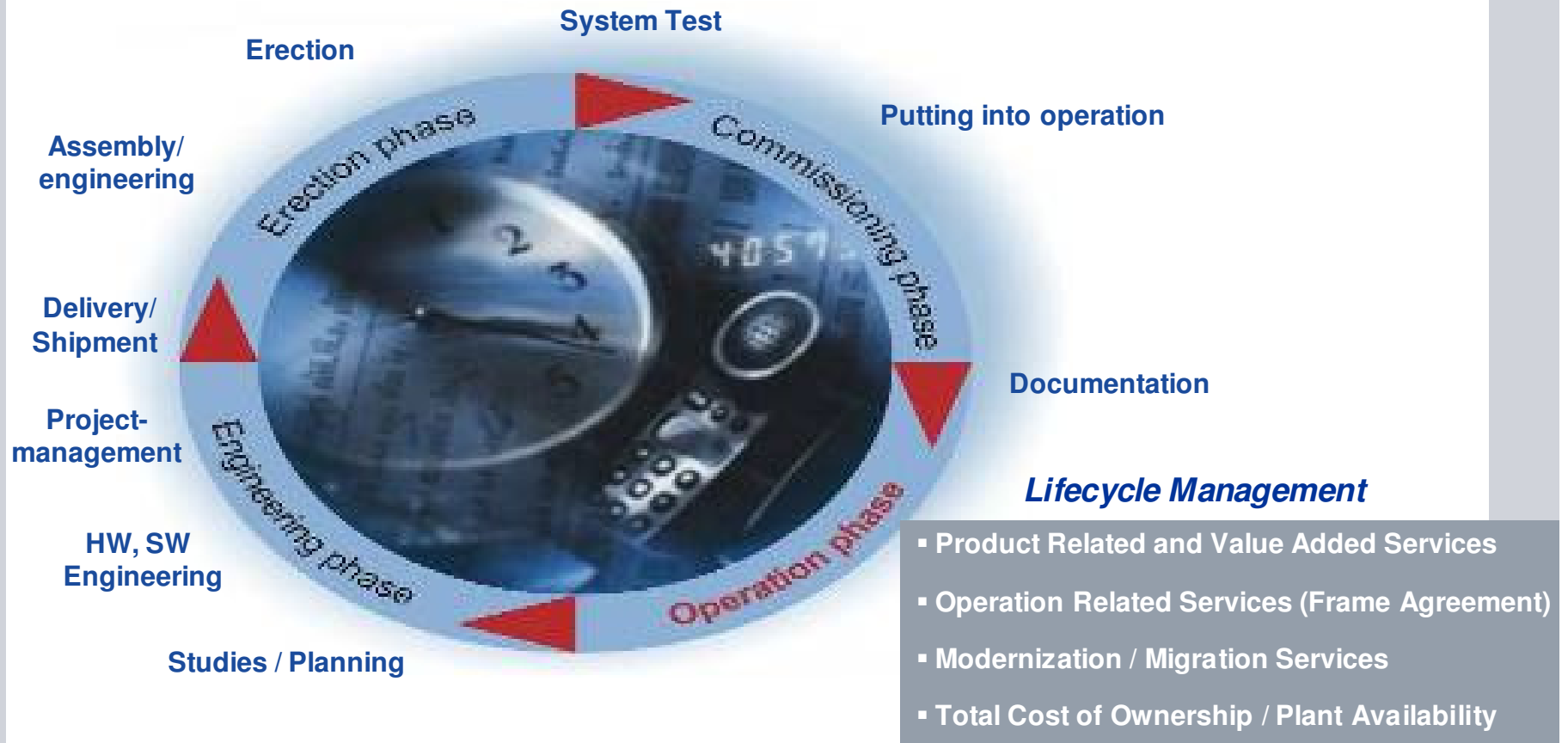

Condition Based Monitoring - Insulation Analysis



Examination of the insulation enables damage to be detected at an early stage. For example: grounding and interturn faults, core burning, and damage to the end winding or laminated core.

Remaining life analysis – the winding seasons due to electric and thermic stress.

For an extensive assessment of a machine's winding, we perform the following measurements:

- Insulation measurement
- Calculation of the polarization index
- Measurement of the loss factor $\tan \delta$
- Measurement of partial discharge (for critical machines during operation as well)
- Measurement of the charge and discharge curves (according to the IEEE standard)

Condition Based Monitoring-Analysis of Electrical Networks

SIEMENS



Voltage curve anomalies, high energy consumption and wrong measured values may be caused by line faults.

To identify weak spots like this and their causes the following analyses are carried out:

- Analysis of system perturbations
- Line fault analysis with measurement of all relevant network parameters
- Analysis of performance in supply systems and frequency converters
- Analysis of harmonics
- Evaluation of the network quality as defined in EN 50160

Prozessoptimization with advanced Diagnostic Functionalities

SIEMENS

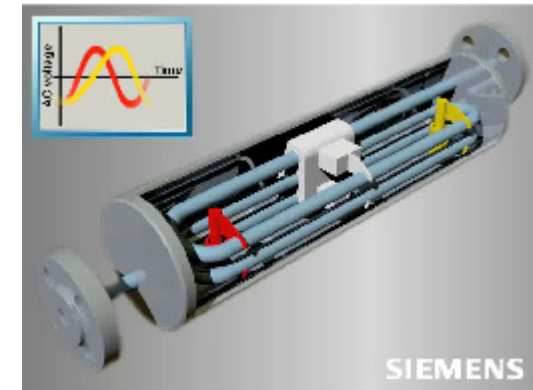
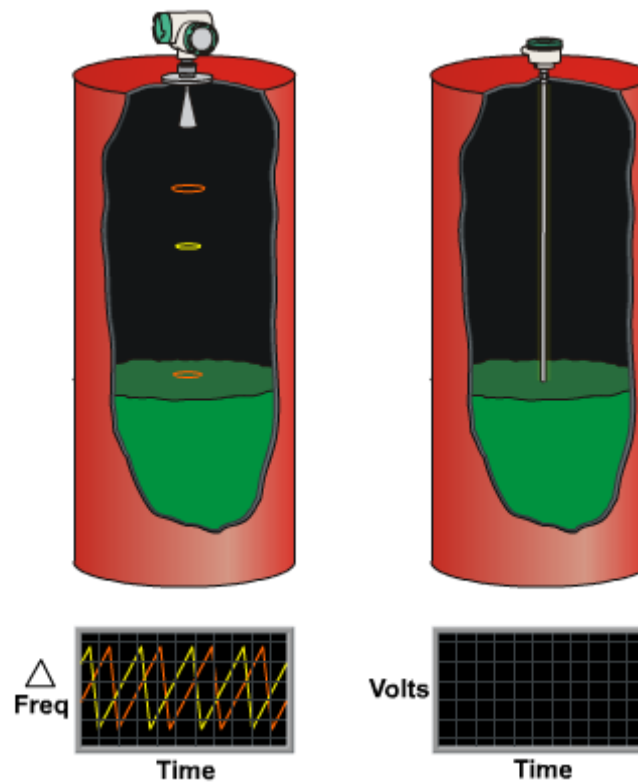

Evaluation of Frequencies / Frequency Shift / Phase Shift / differential Frequencies/ Frequency Attenuation

Flow Technologies

Flow, Volume, Density, Concentration and Massflowmeters

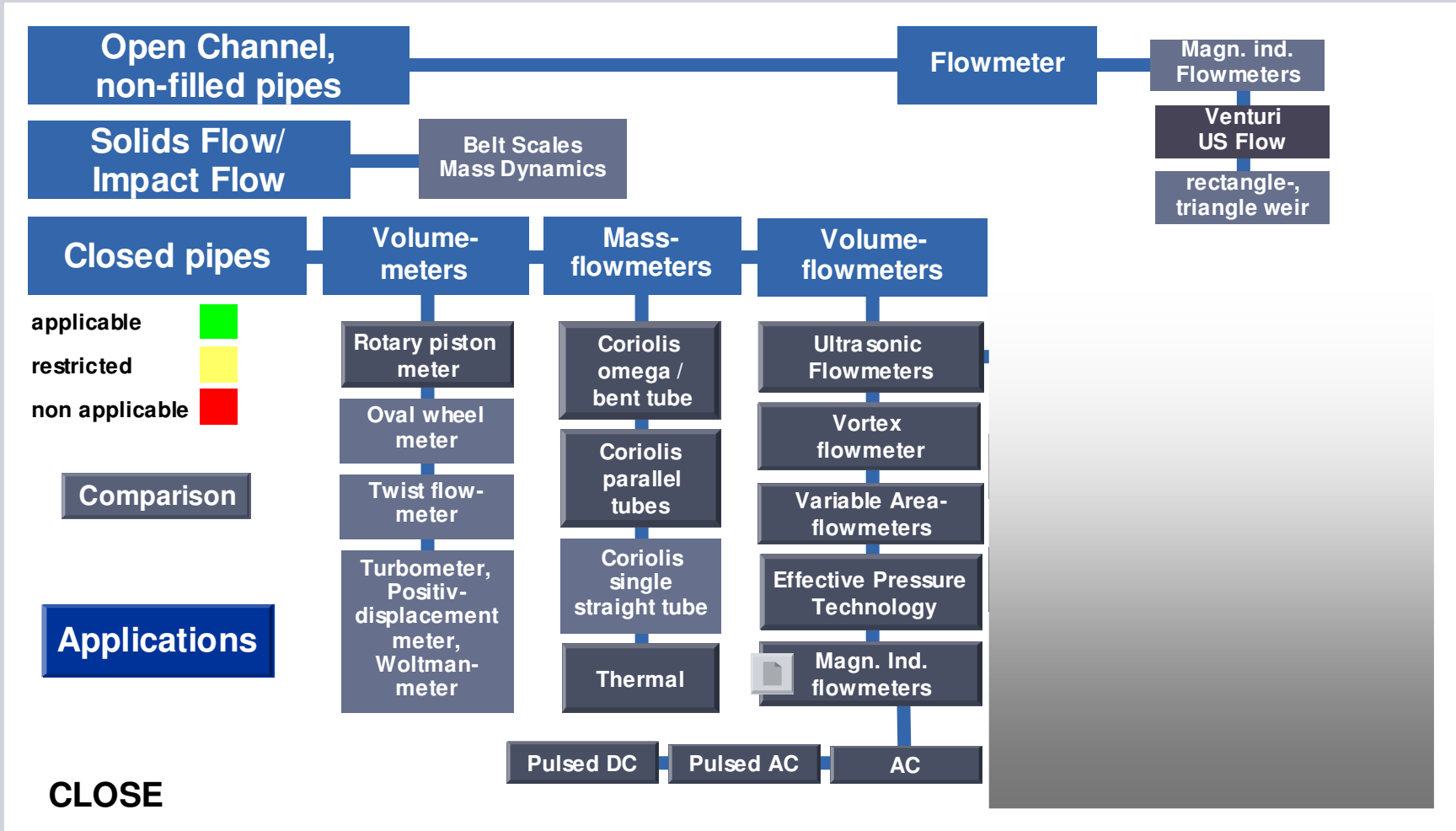

Technology Comparison

e.g. Flow, Volume, Density, Concentration Mass - Detection

SIEMENS

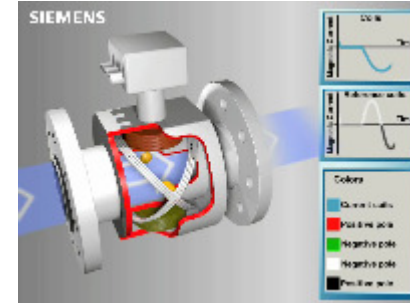
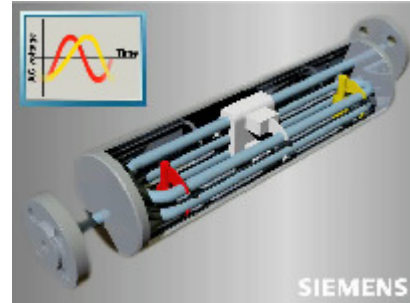
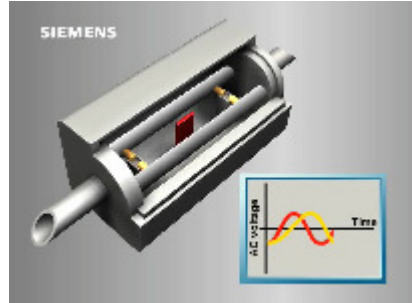
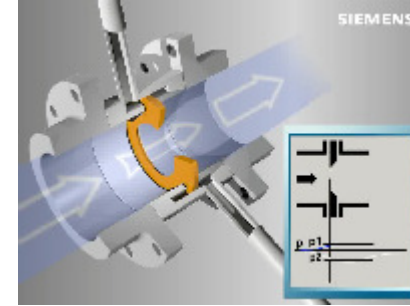
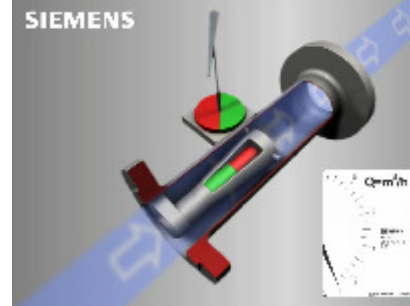
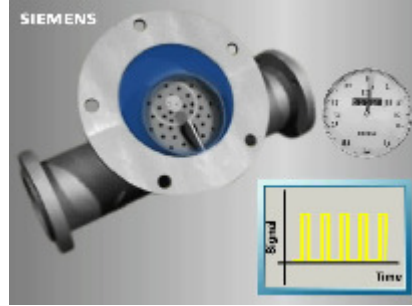
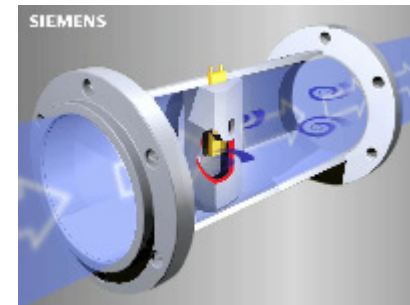
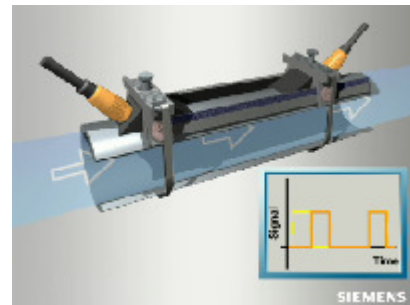
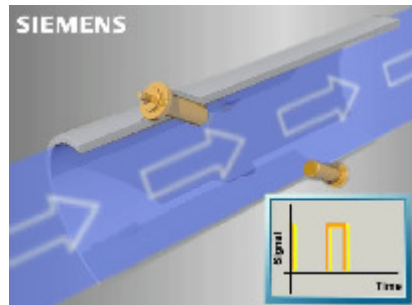

Pulsed AC / DC , Rectified Field MAG Flowmeters Flow and Condition Monitoring

SIEMENS

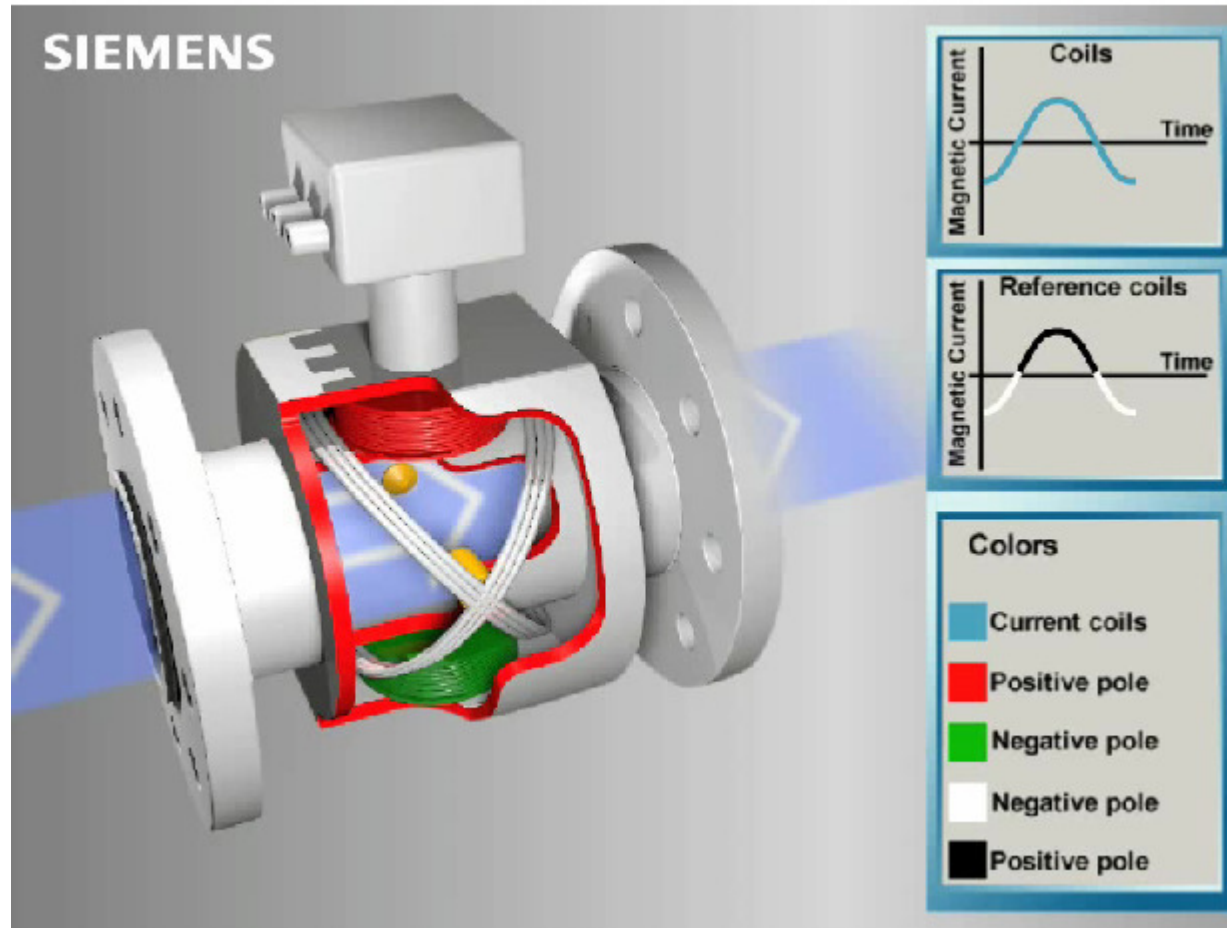

Magnetic Flowmeters Condition Monitoring Metal Particles in Media

SIEMENS

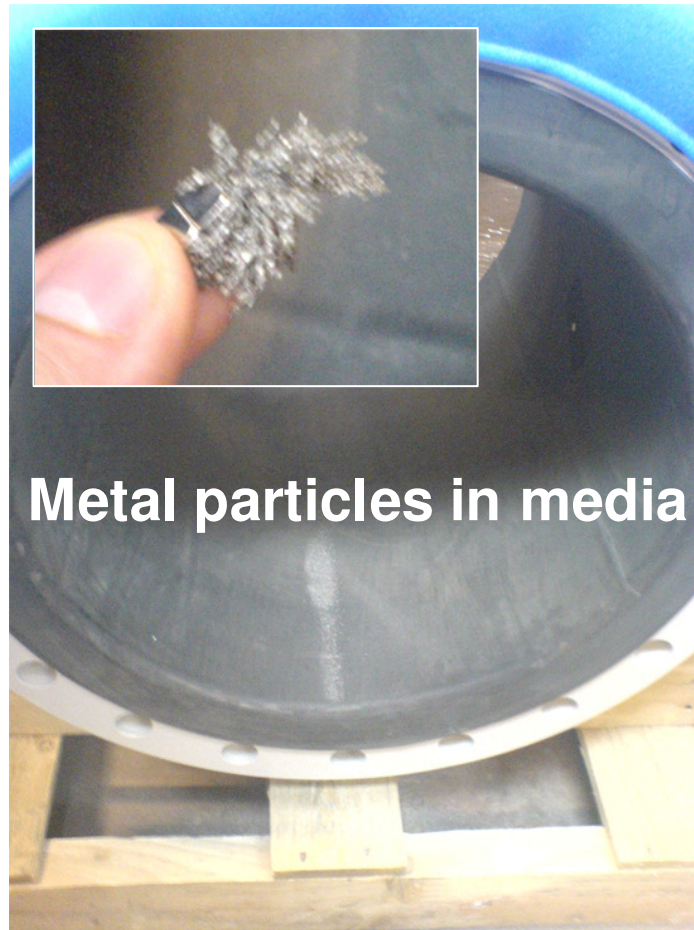

Effective Pressure Flow Technologies Flow and Condition Monitoring

SIEMENS

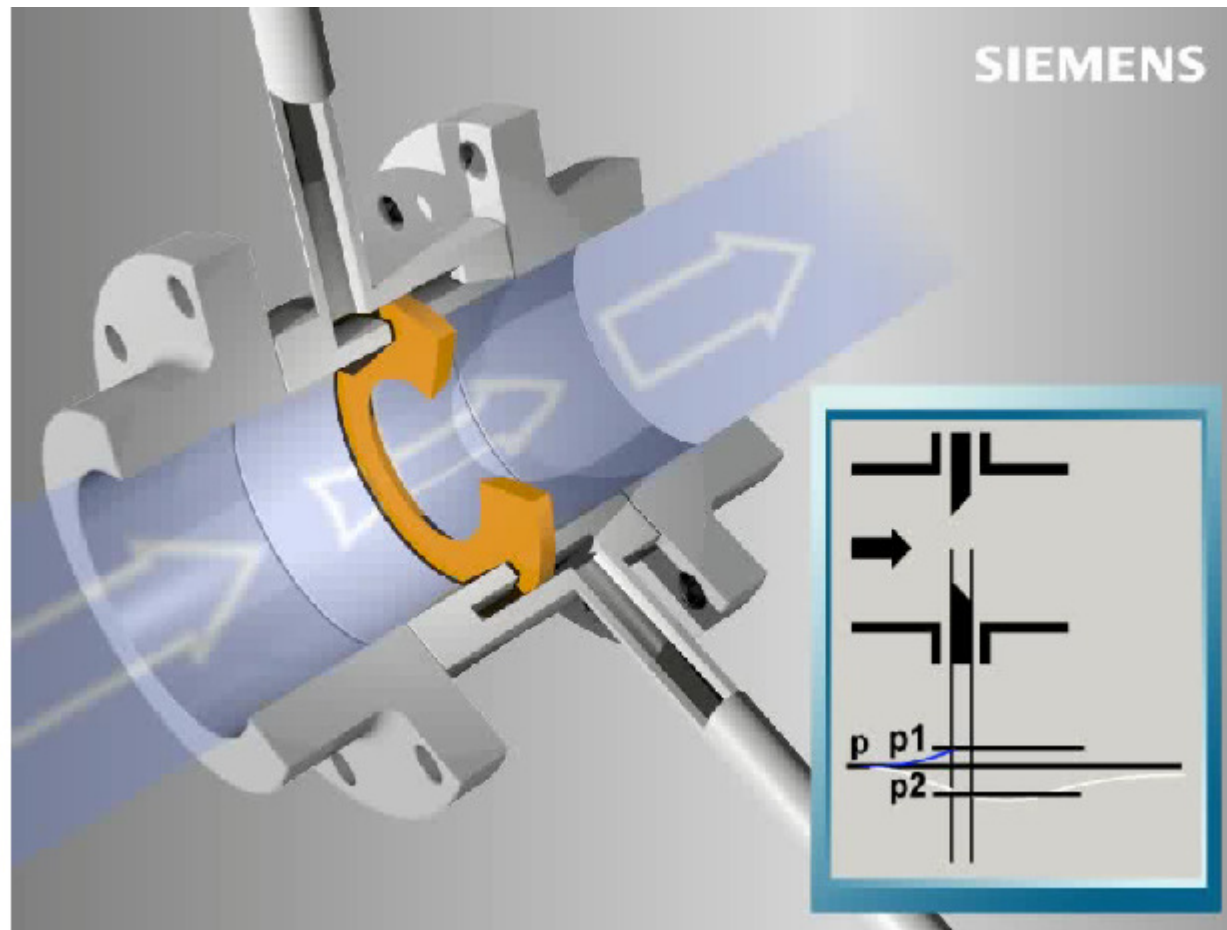

Differential Pressure Condition Monitoring Fouling of Impulse Line

SIEMENS



Ultrasonic Clamp on Flow Meters

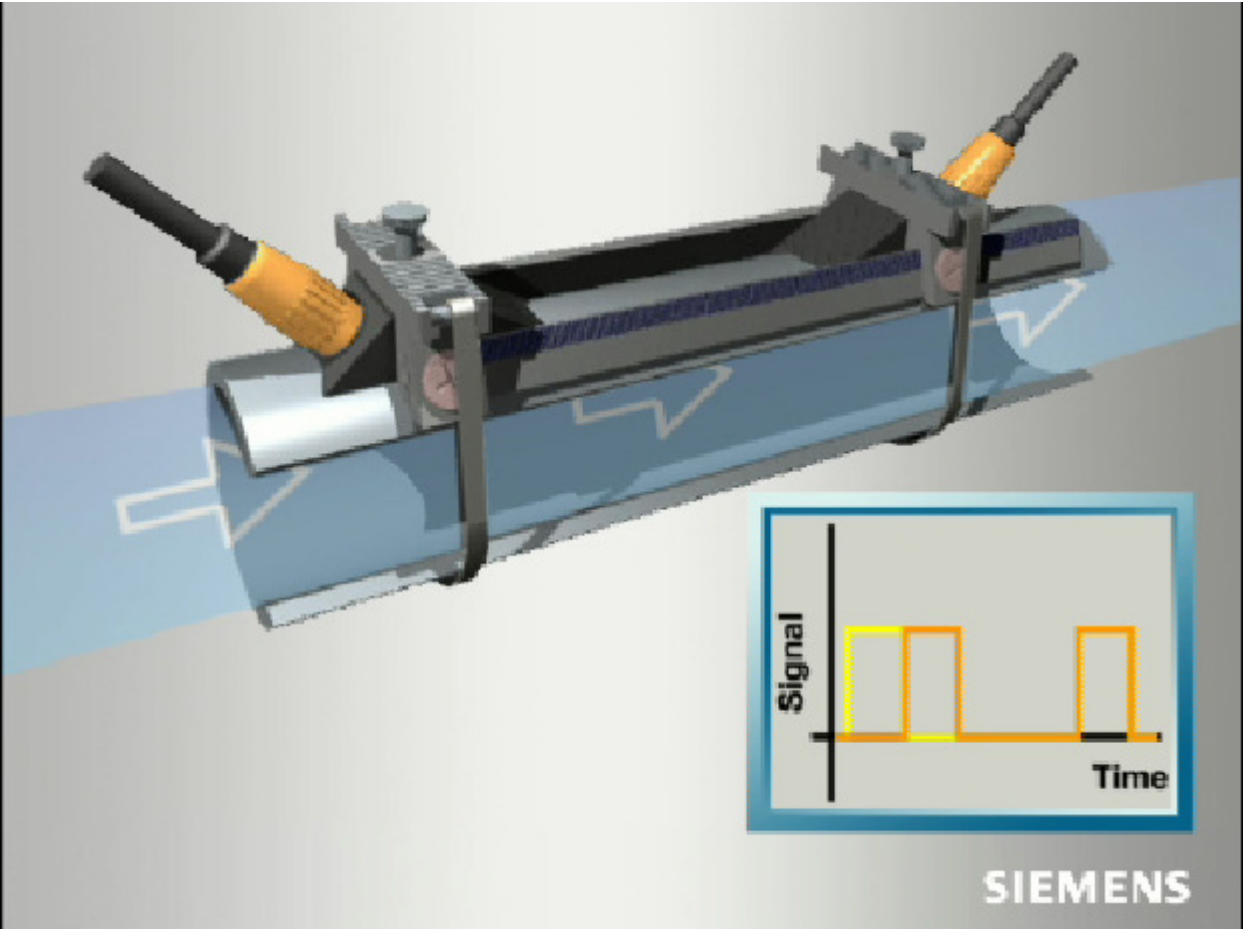

Optimization and Reduction on Waste of Natural Sources and Environmental Cleaning Energy and Costs of more than 1 mio €

SIEMENS

Condition Monitoring an Durchflussleitungen zur Optimierung von Pumpen- und Kompressorleistungen zur Erhöhung der Energie - Effizienz, Leckage Detektion und Monitoring von Rohrverschmutzungen zur Reduzierung von Reinigungsenergien, Pumpen- und Kompressorenergien, Umweltverschmutzungen, Verschwendung von Rohstoffen sowie Betriebsenergien.



Einsparungspotential:

- Erfassung und Optimierung von Betriebskonditionen an Flüssigkeits- und Gasdurchflussleitungen zur Optimierung der Energie – Effizienz, Produkttransportkosten sowie Anlagenverfügbarkeit und Umweltbelastungen.
- Detektion von Verstopfungen, Verschmutzungen, Verschleiss und Leckagen die zur Erhöhung des Energiebedarfes beim betreiben von Durchflussleitungen führen. In mehrern Leckagesituationen bei Ölpipelines konnten durch **Früherkennungen die Verschwendung von Rohmaterialien um mehrer Millionen € und die Kosten für Reinigung der Umwelt und Reinigungsenergien sowie Folgeschäden zusätzlich um mehrere Millionen € verhindert werden.**

Level Technologies

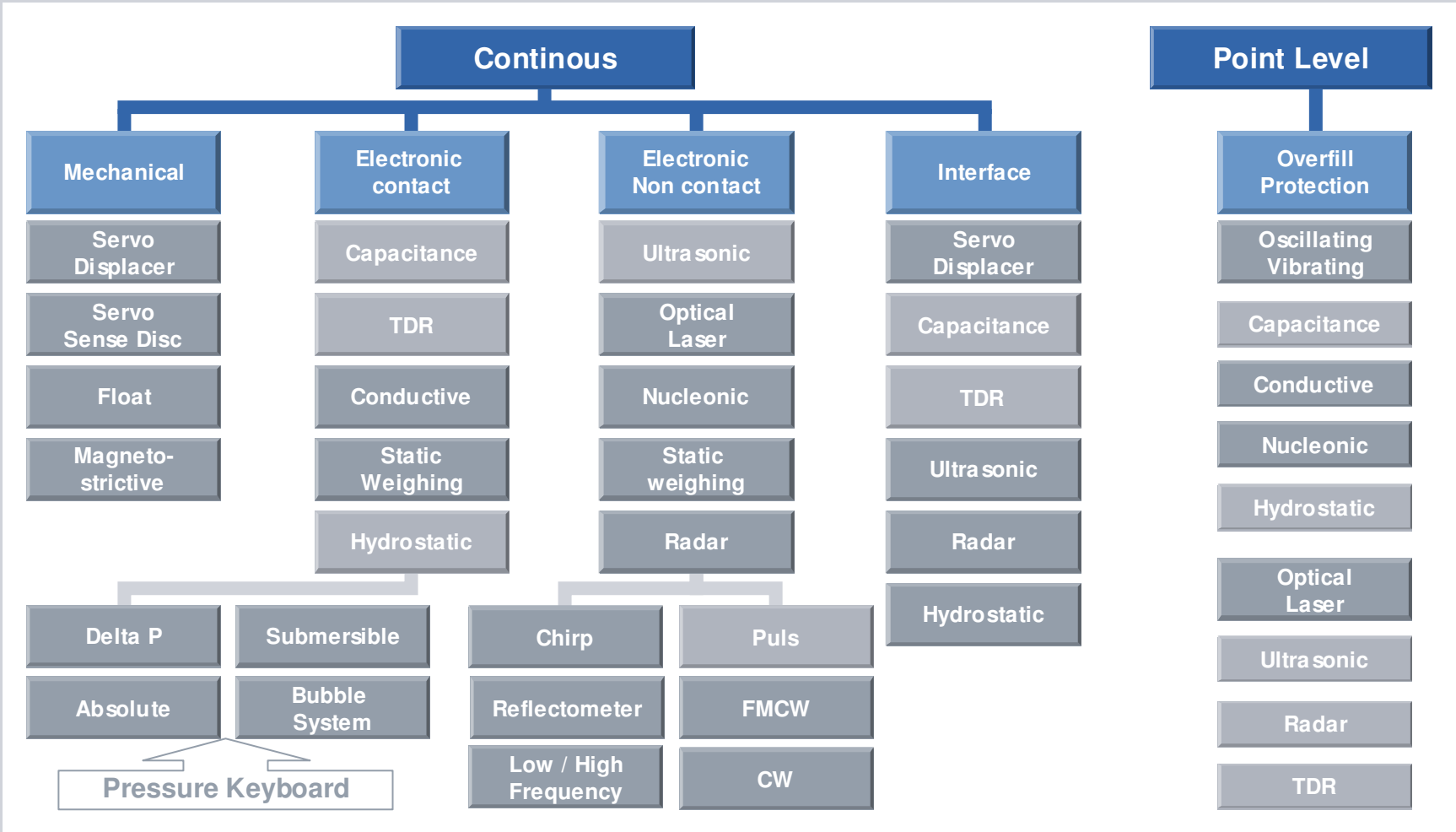

Level Measurement Technologies

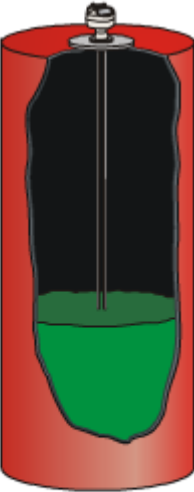
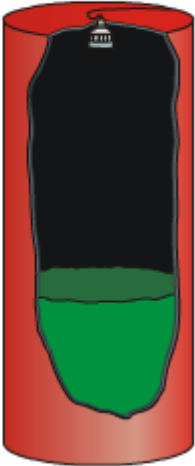
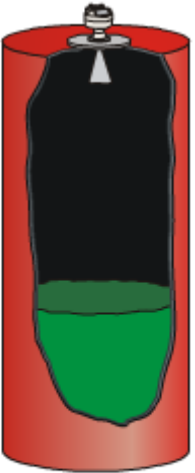
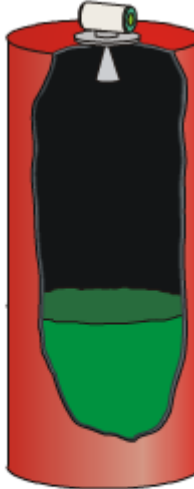
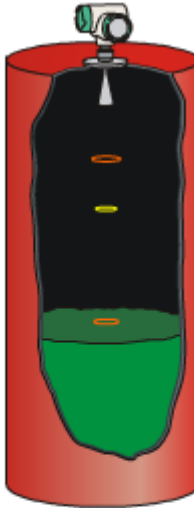
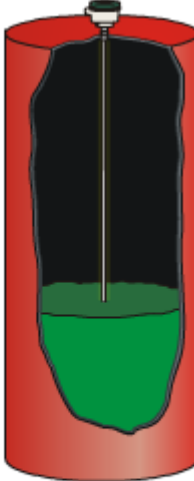
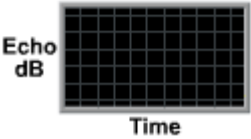
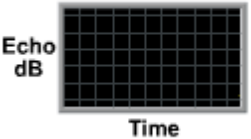
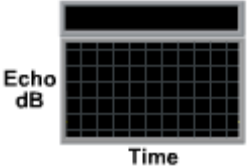
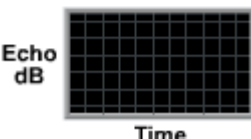
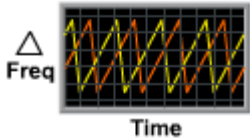
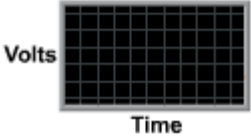
Sitrans LG	Sitrans LU	Sitrans LR	Sitrans LR	Sitrans LR	Sitrans LC
Guided Wave Radar / TDR	Ultrasonic	2 wire Pulse Radar	4 wire Pulse Radar	4 wire FMCW Radar	Capacitance
					
					

Interface LEVEL TECHNOLOGIES Technology Description Application Simulation

High Temperature Application with Level-Radar
on Polymer and Paraffin Reactors (Cond.Monitoring)

SIEMENS

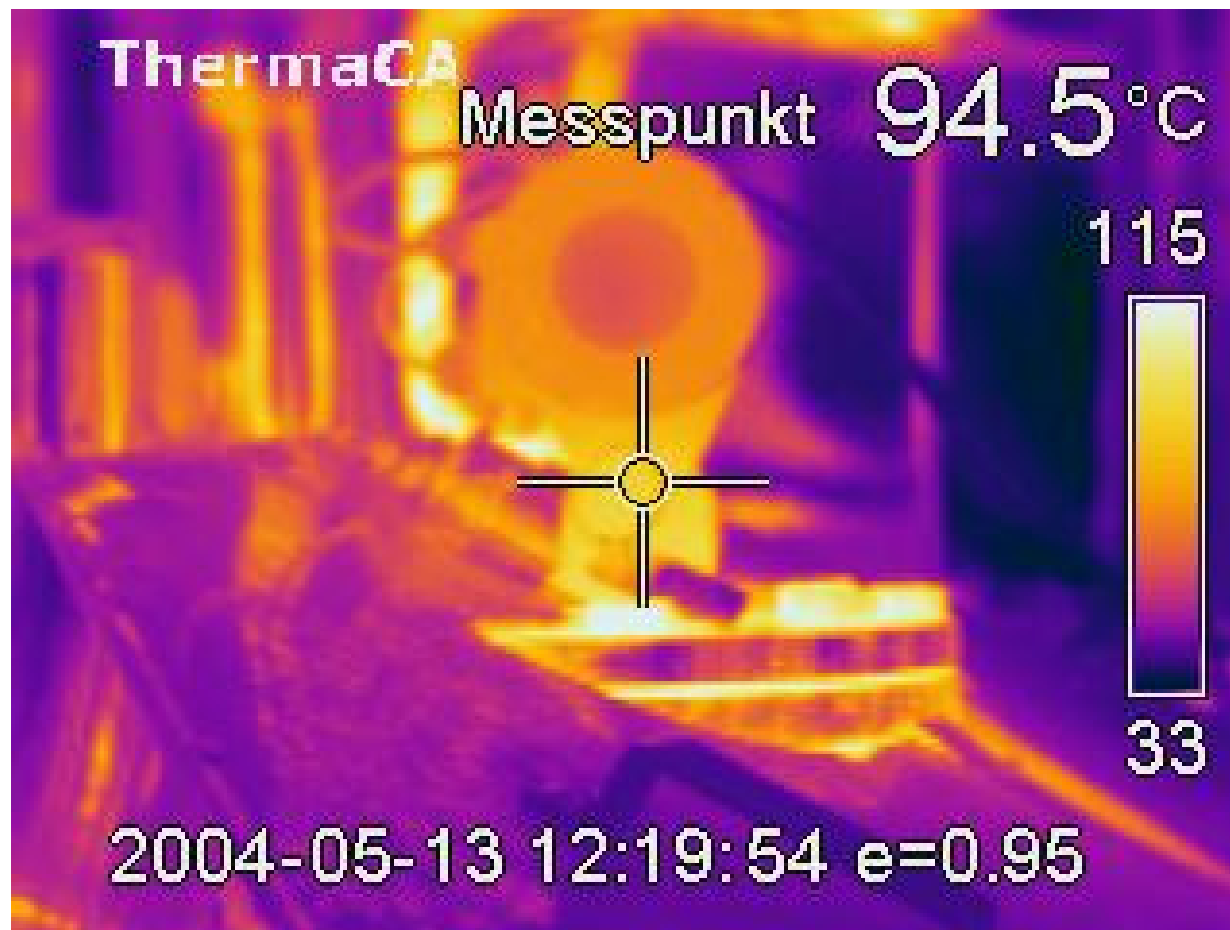

Level-Radar High Temp Unit with 200 mm heat extension

SIEMENS

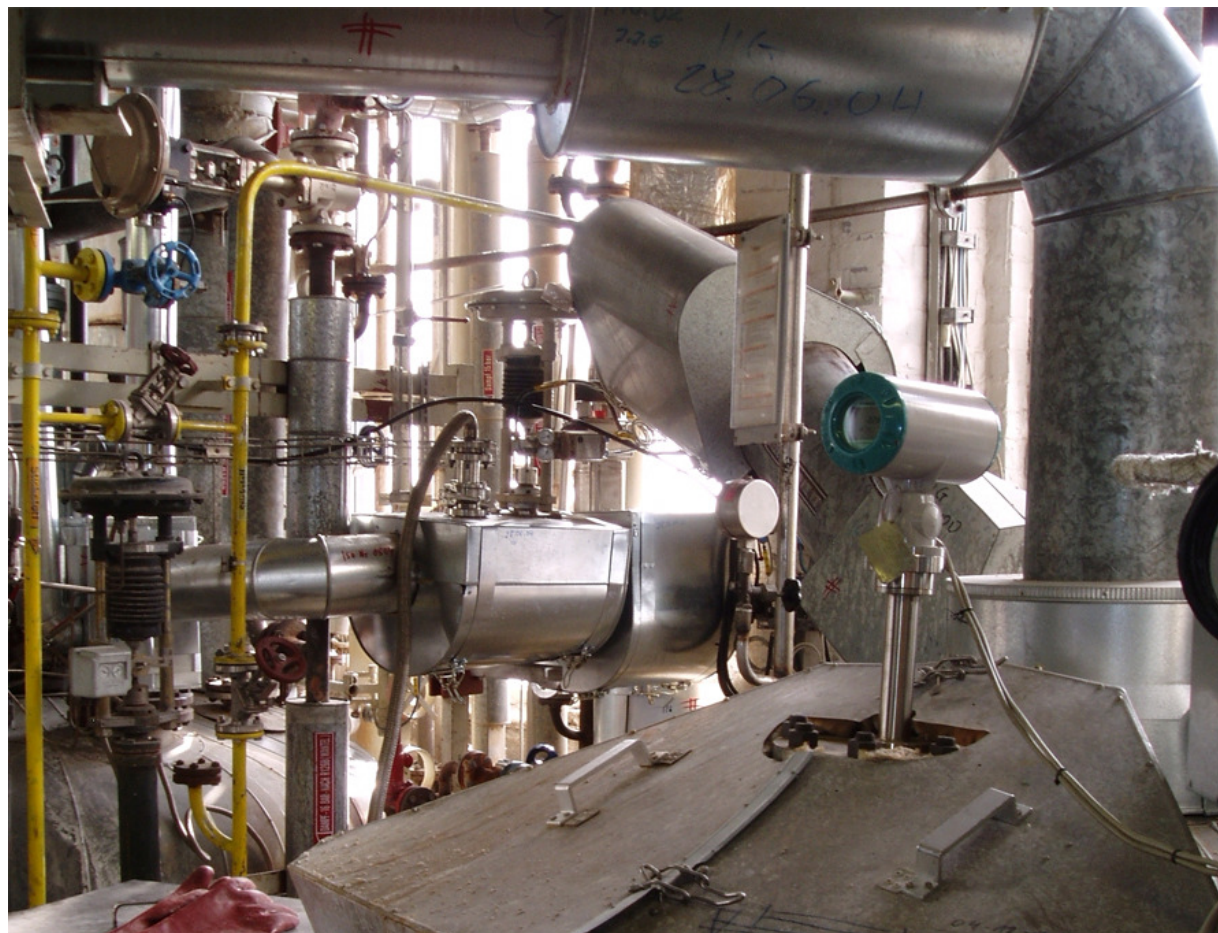

Production Process Paraffin

SIEMENS

Thermographie after new configuration (Management)



Process Optimization with Instrumentation Technologies Styrene / Styrol Process Reactor

SIEMENS

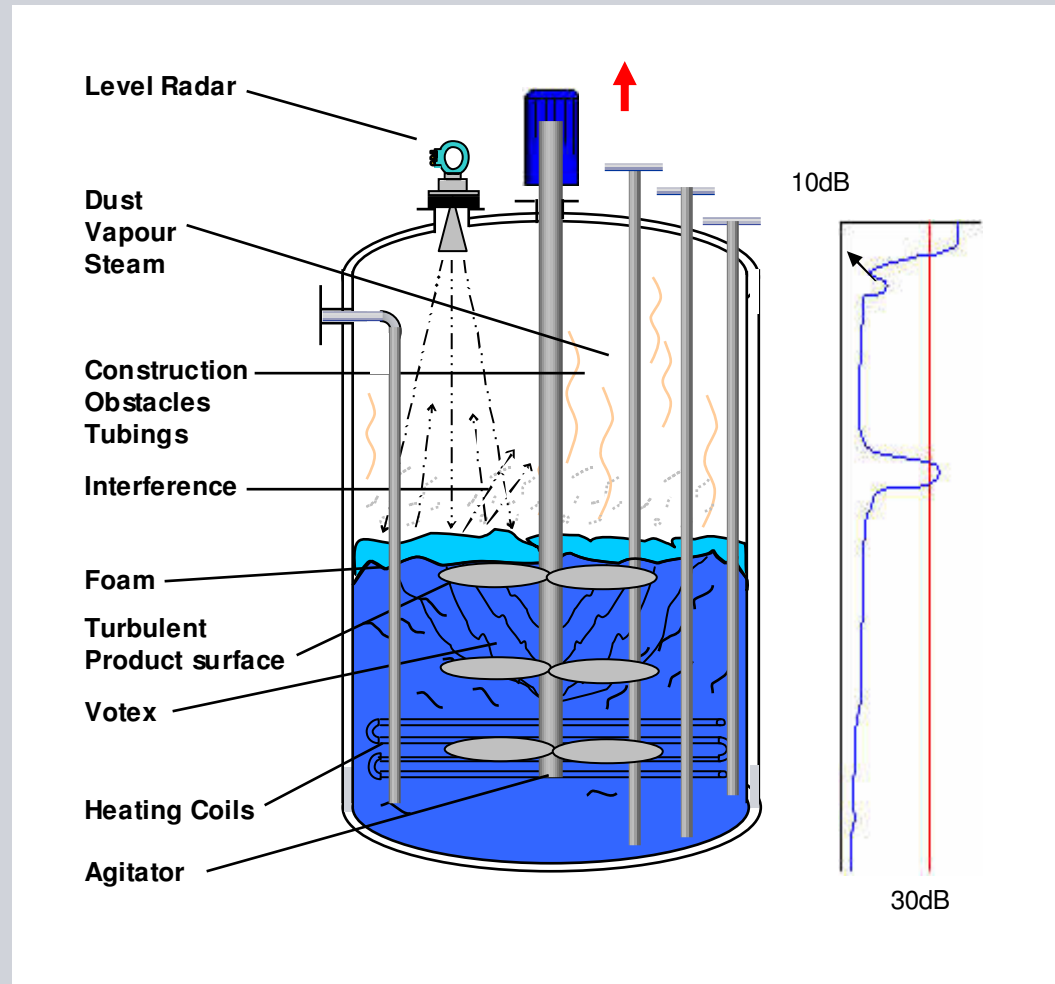

Energy Savings due to reduced Down Time and Cleaning costs of 100.000€/month on each Reactor

SIEMENS

Produktionsoptimierung in Prozessreaktoren

als Teil von Asset Management.

Optimierung der Energiebilanz, Produktionskosten beim Anfahren von Produktionsprozessen, der Produktionseffizienz sowie Reduzierbarkeit der Produktionsqualität und Quantität sowie Erhöhung der Energie Effizienz in der Prozess – Industrie

Einsparungspotential

- Reduzierung von Energiekosten beim Anfahren von Produktionsprozessen
- Erhöhung der Energie-Effizienz hinsichtlich Einsparung bei Heizprozessen und Reinigungsprozessen
- Erhöhung der Anlagenverfügbarkeit
- Optimierung der Produktionsqualität durch Erhöhung der Messsicherheit von Sensoren sowie Monitoring von Prozessparamern wie Schaumbildung, Verschmutzung und Überfüllung
- Das Energieeinsparungspotential wurde vom Anlagenbetreiber mit **100.000€ im Monat** pro Reaktor ermittelt

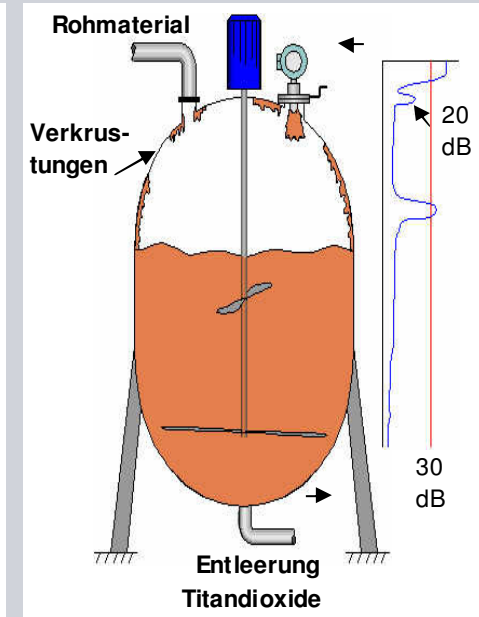
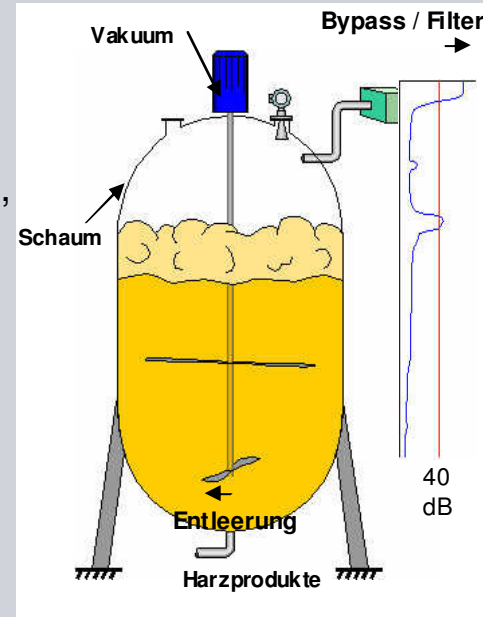

Pressure Technologies

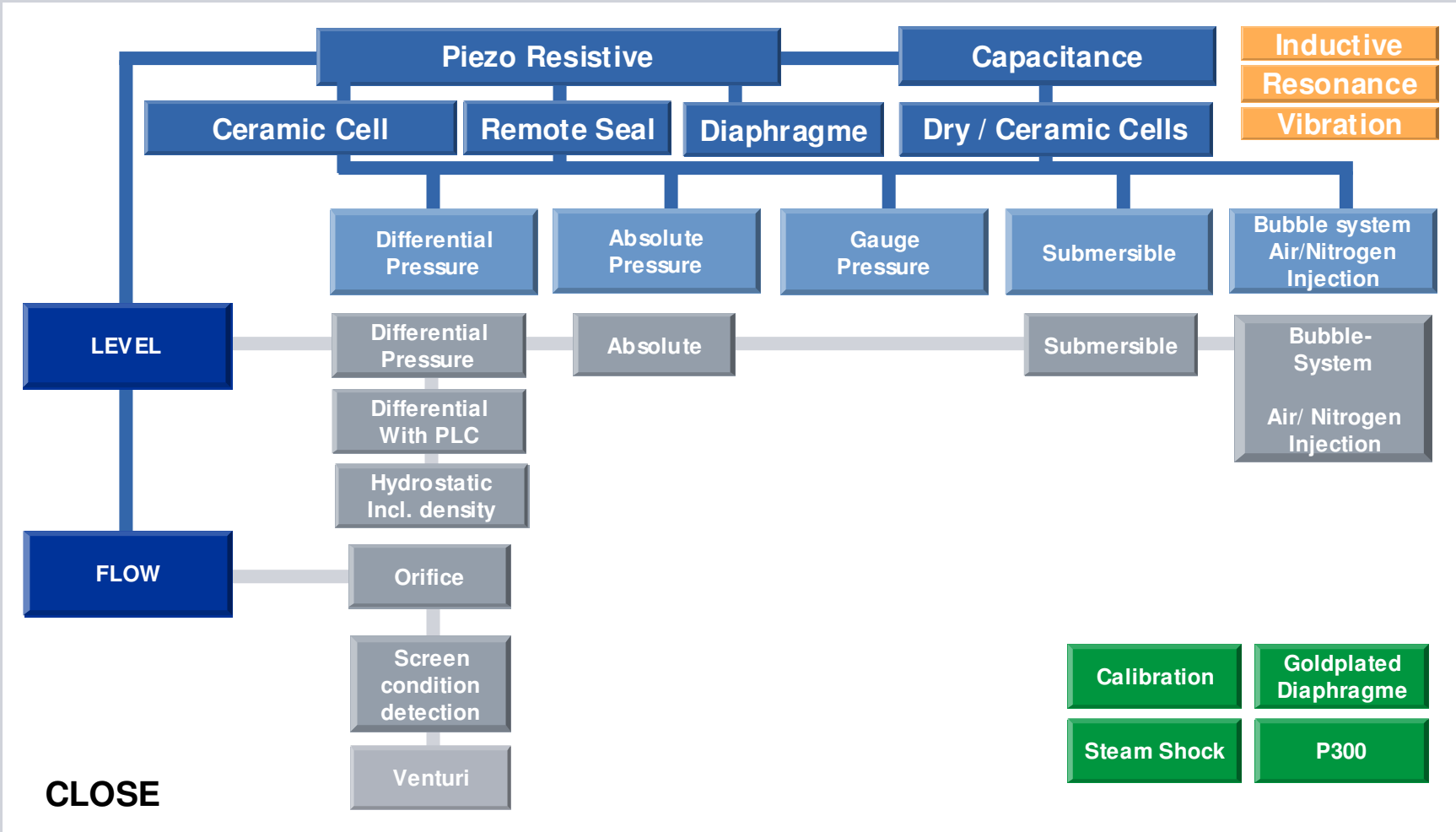

Pressure Measurement Condition Monitoring - Fouling of Membrane

SIEMENS



Acoustic Condition Monitoring Pump Worn and Efficiency Monitoring

SIEMENS

Hose Membran Pump

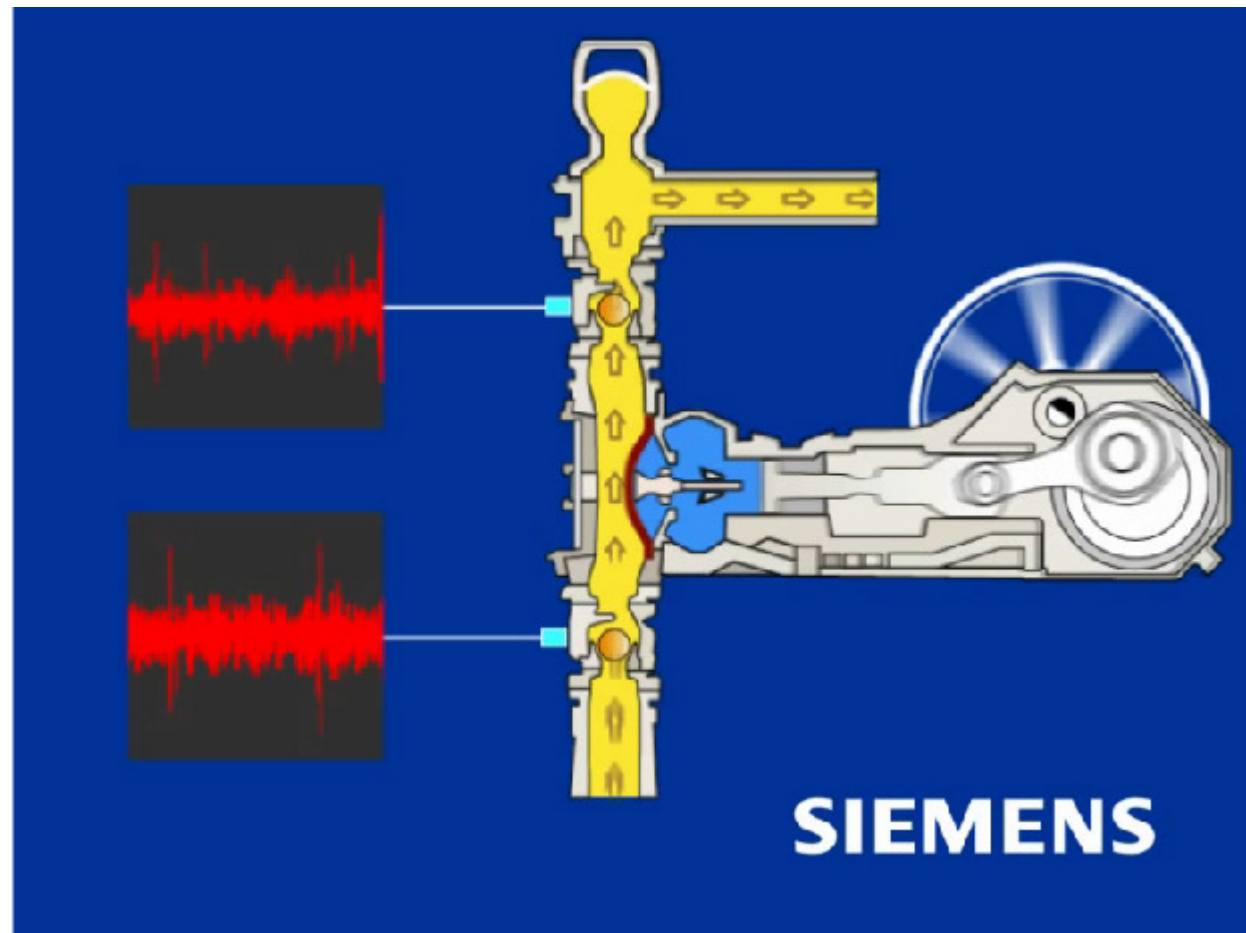

Oscillating Displacement Pump



Positioner Technologies

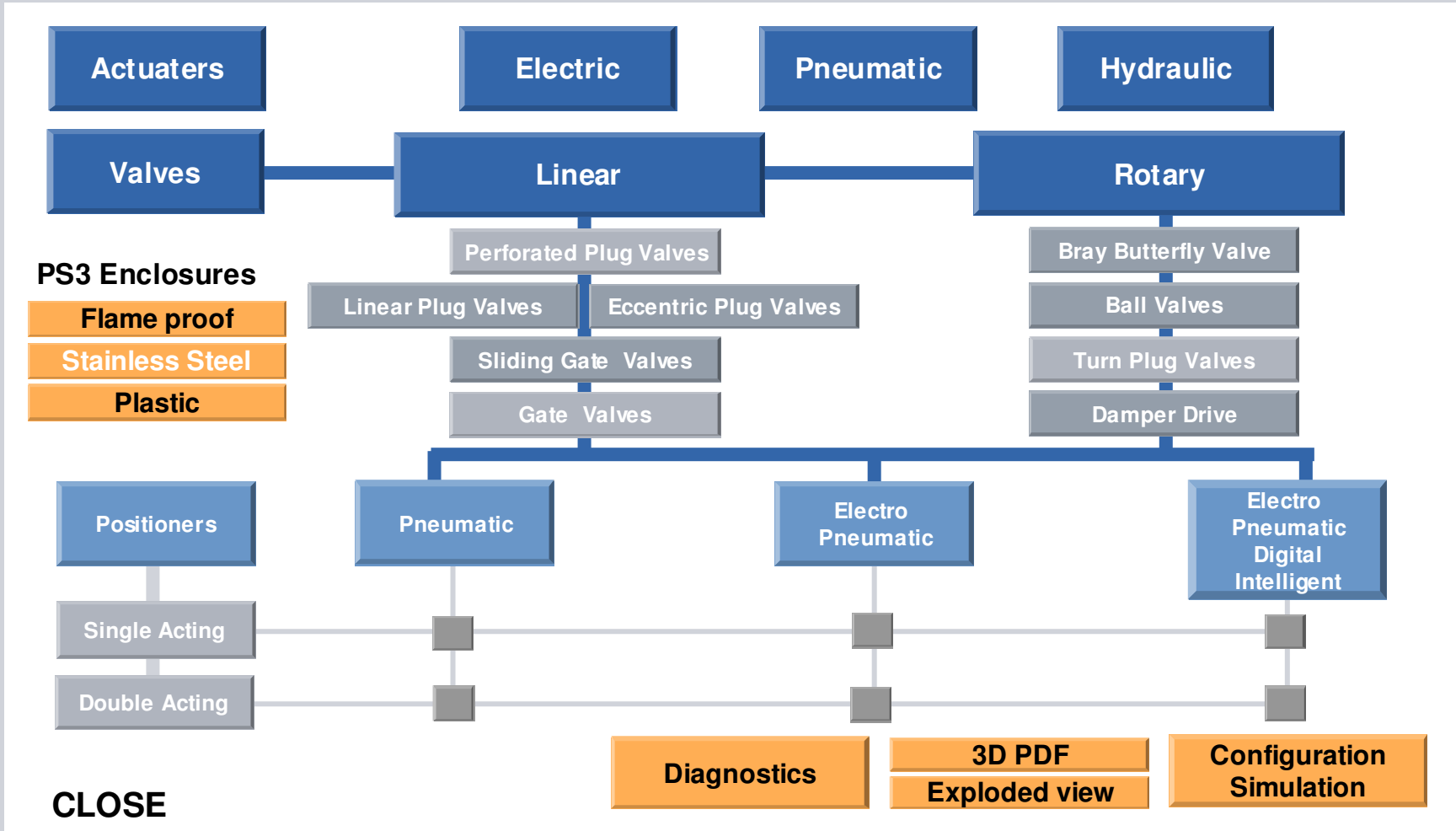

Valve Condition Monitoring Preventative Maintenance

SIEMENS

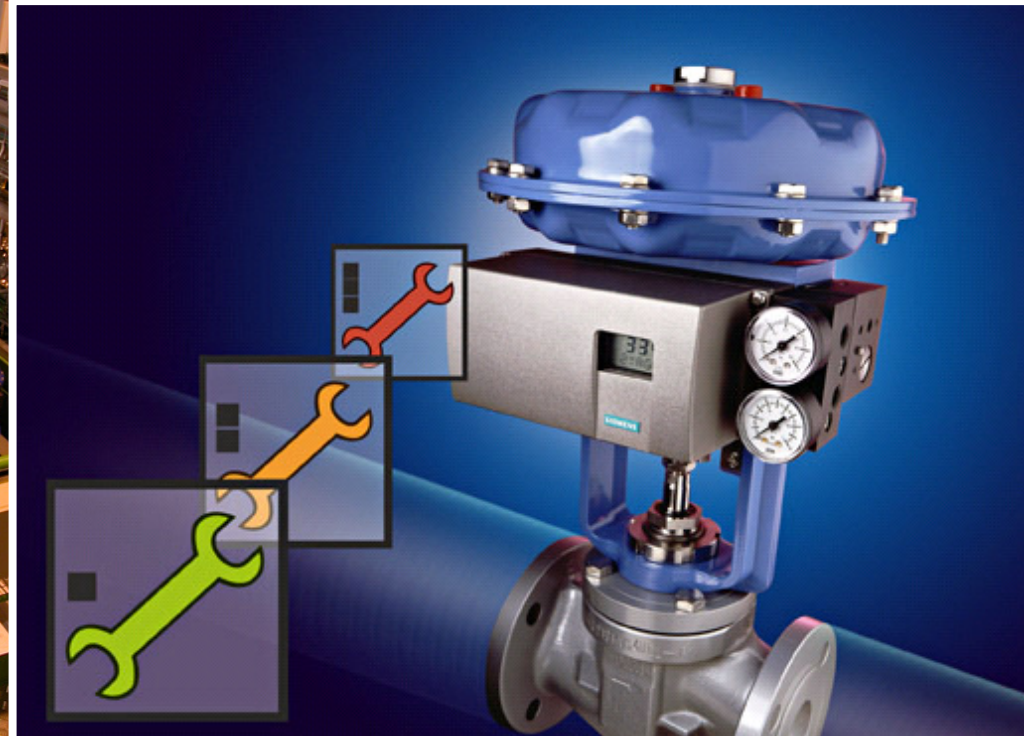

Asset Management / TCO / Condition Management Valve and Positioner Configuration Optimization

SIEMENS

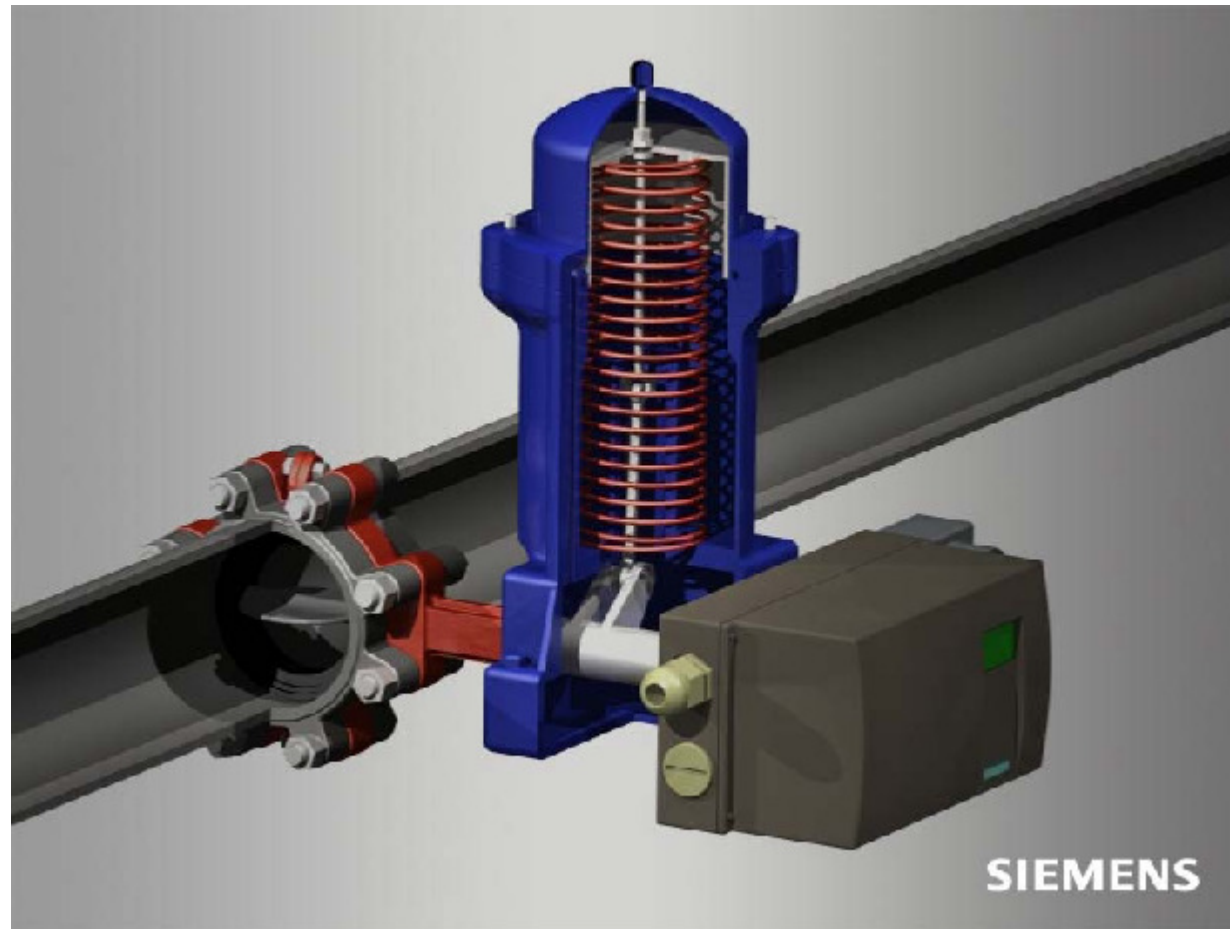

Condition Monitoring and Management on Valves and Flow Lines

SIEMENS



Energie Savings on intelligent electr.pneumatic Valve Positioners 500.000€/a
Energy Savings on Motors driving pumps of 137.000€/a

Condition Monitoring an Ventilen, Pumpen, Filtern, Kompressoren

Optimierung von Energie - Effizienz, Produktionseffektivität und Operationskosten mit intelligenten Prozess-Instrumentierungstechnologien und Sensoren

Einsparungspotential

- Erfassung und Optimierung von Betriebskondition an Aggregaten und Aktoren zur Erhöhung der Energie – Effizienz von Antrieben und Versorgungsenergien,
- Erhöhung der Produktionseffizienz sowie Reduzierung der Maintenance Kosten
- Detektion von Verstopfungen, Verschmutzungen, Verschleiss und Leckagen die zur Erhöhung des Energiebedarfes beim betreiben von Anlagen/ Aggregaten führen.
- Einleitung von Lösungen zur Verhinderung bzw. Reduzierung von ungeplanten Prozesszuständen die zur Erhöhung der Produktions- und Energieeffizienz führen.
- Am Beispiel von elektro-pneumatischen intelligenten Ventil-Stellungsreglern im Vergleich zu konventionellen Stellungsreglern liegt die durchschnittliche Druckluftersparnis bei ca. 6.000 m³ pro Jahr was einer Ersparnis von ca. 500€ entspricht. Bei einem mittleren Betrieb mit 1000 Ventil-Stellungsreglern entspricht das einer **Energieersparnis von ca. 500.000 € pro Jahr**.
- Durch Wirkungsgradverlust und Falschauslegungen von Pumpen bei 5% erhöhter Leistungsaufnahme ergibt sich folgender **erhöhter Energieverbrauch: Motor 100KW bei Betrieb von 300Tagen – 720.000 KWh = 137.000€/Jahr**

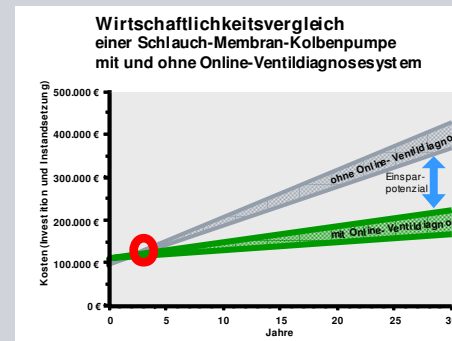
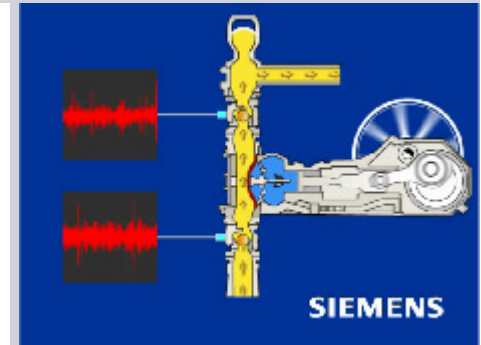
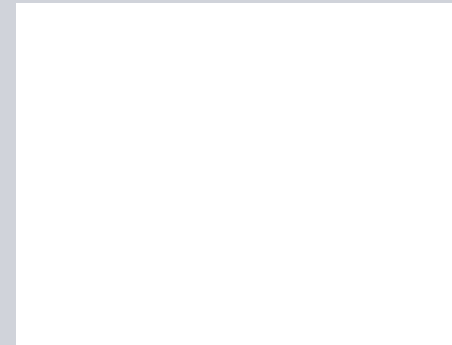

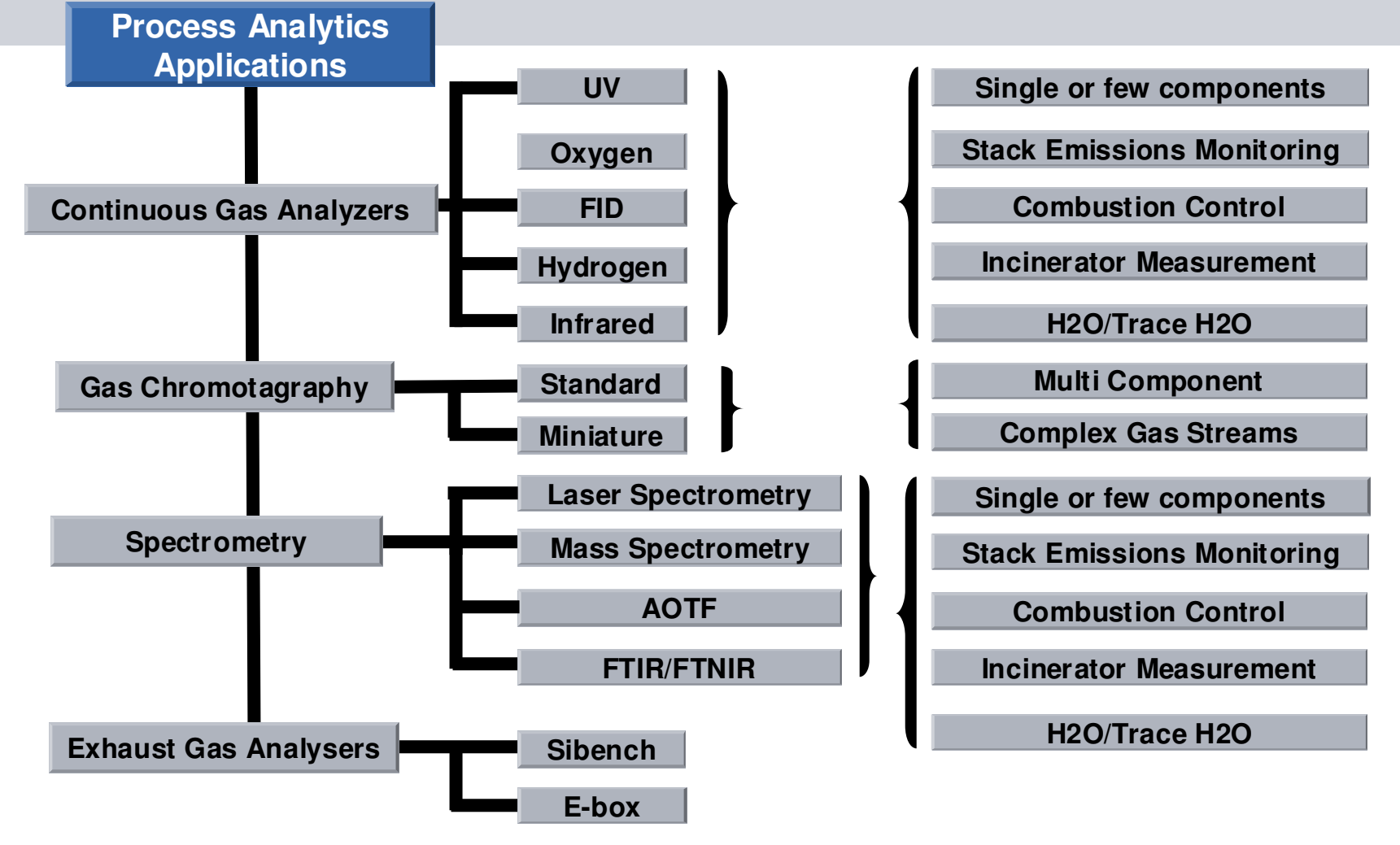

Liquid Analytics

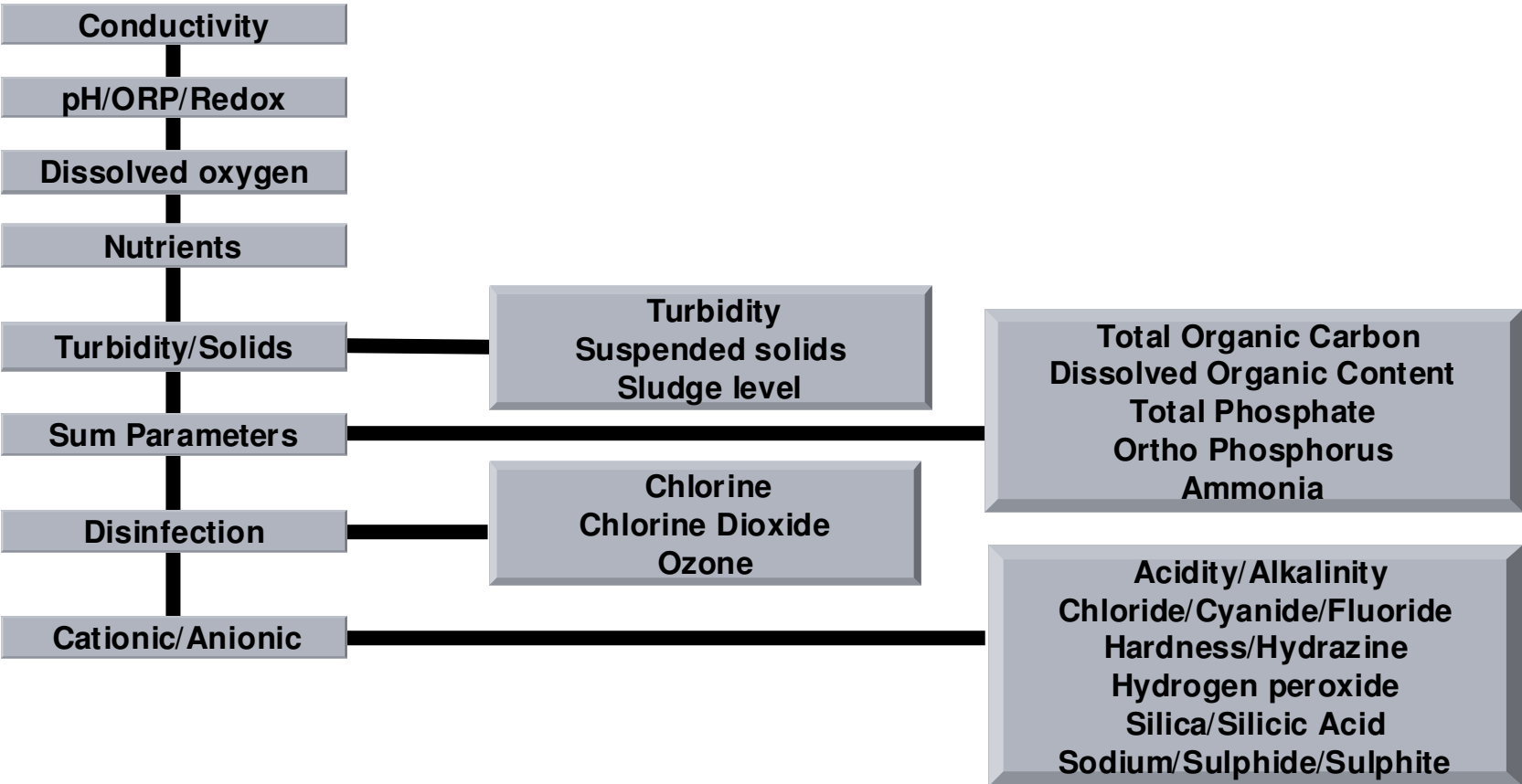

Recovery of Hydrocarbons with an Energy Equivalence of 7mio Liter of Cruide Oil per year

SIEMENS

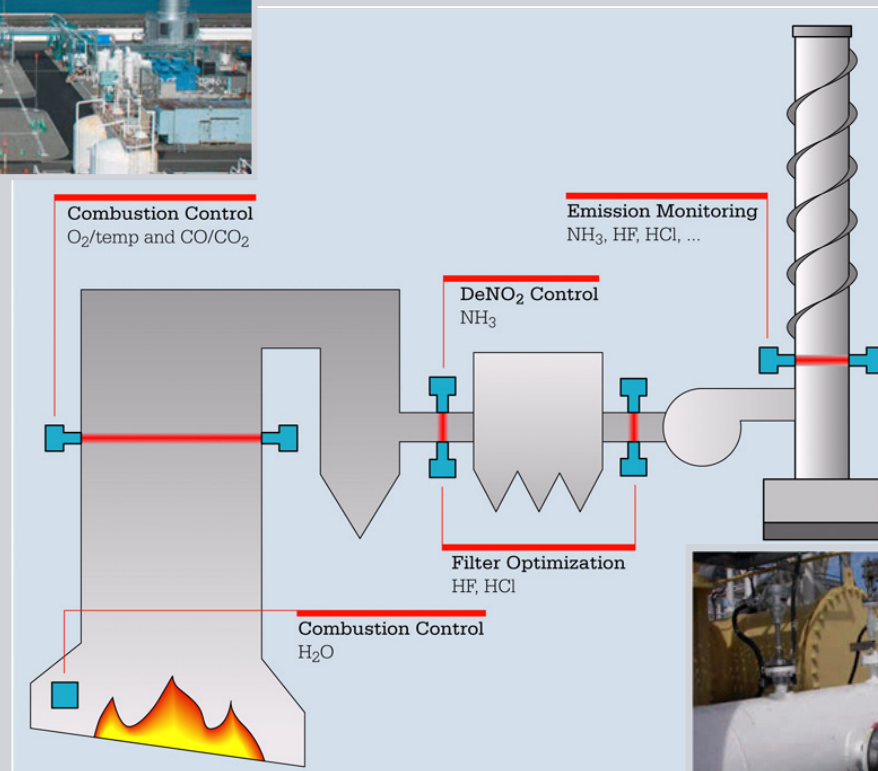

Industry Segmentation

Bioethanol Production Processes

SIEMENS

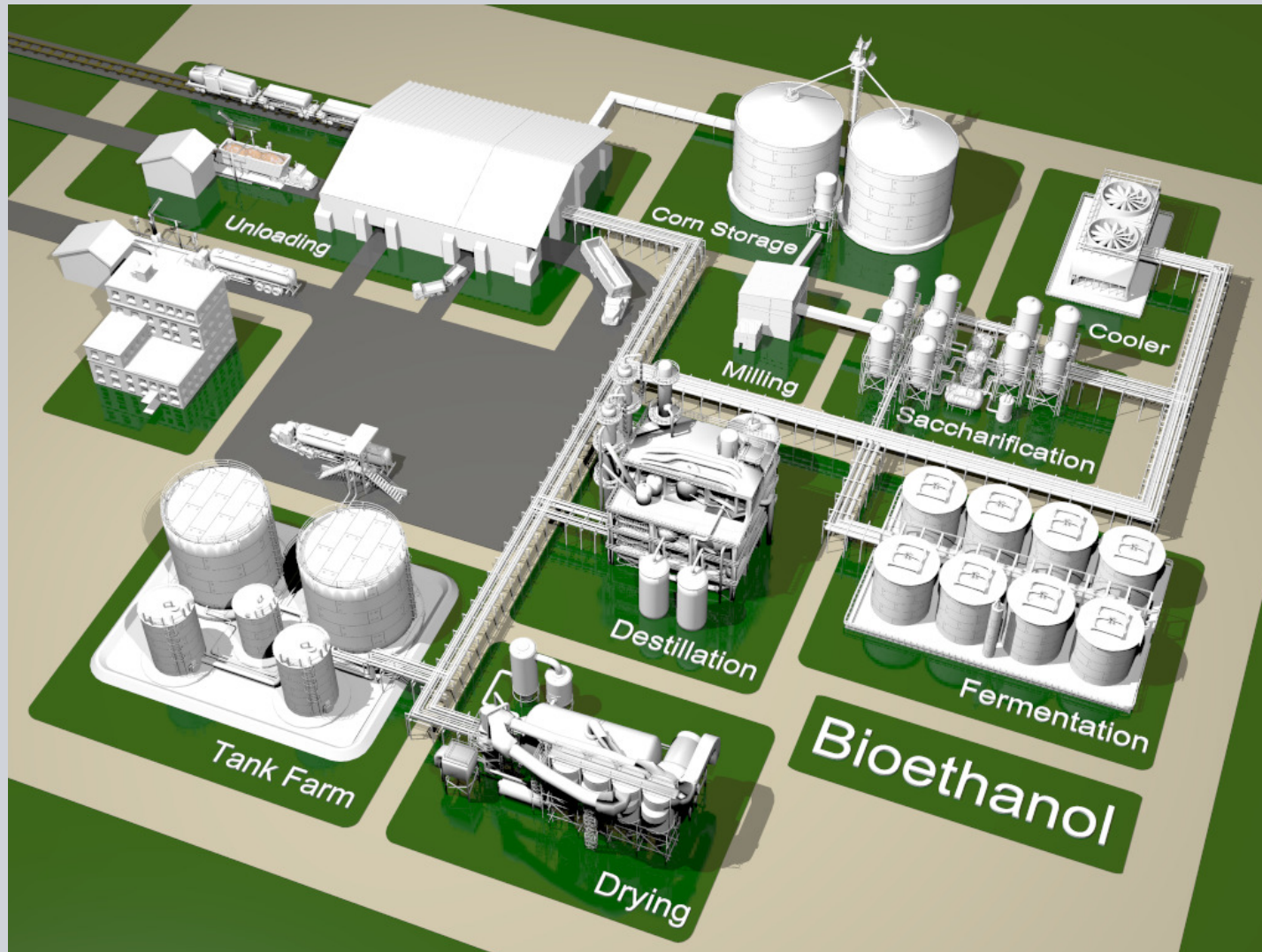

Product Fit for Ethanol Applications

SIEMENS

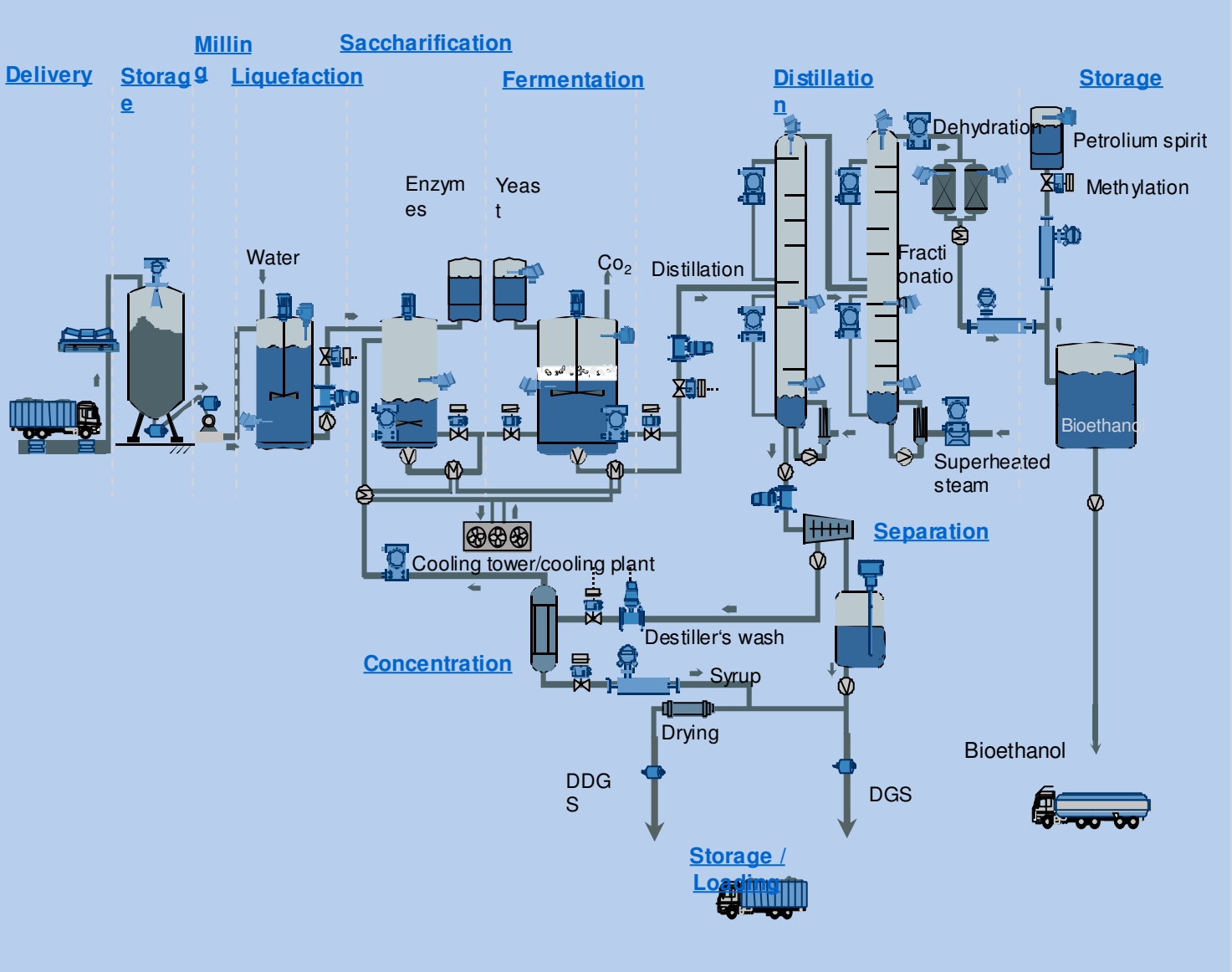

Industry Segment Biodiesel Production Process

SIEMENS

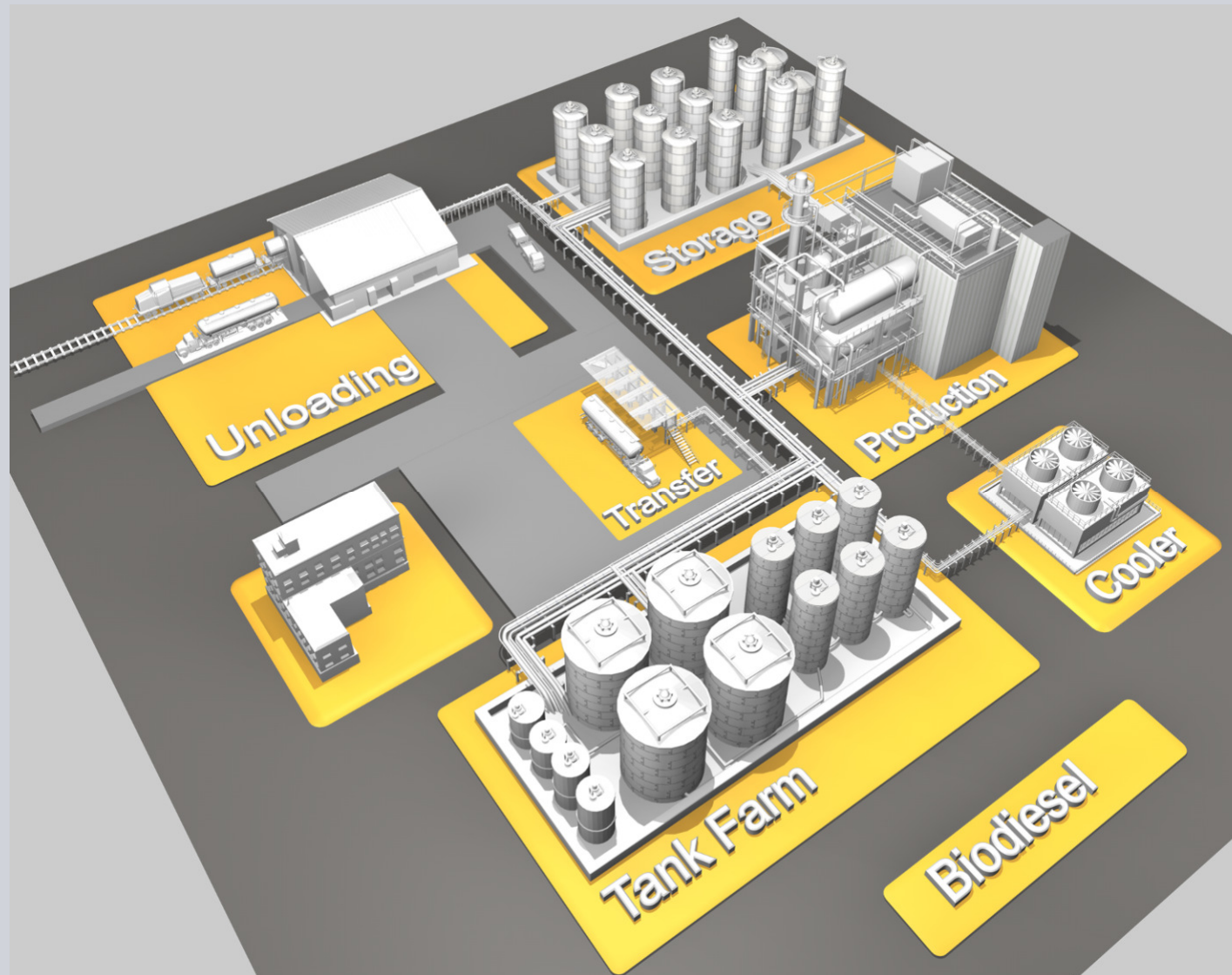

Biodiesel Production Process Flow Chart

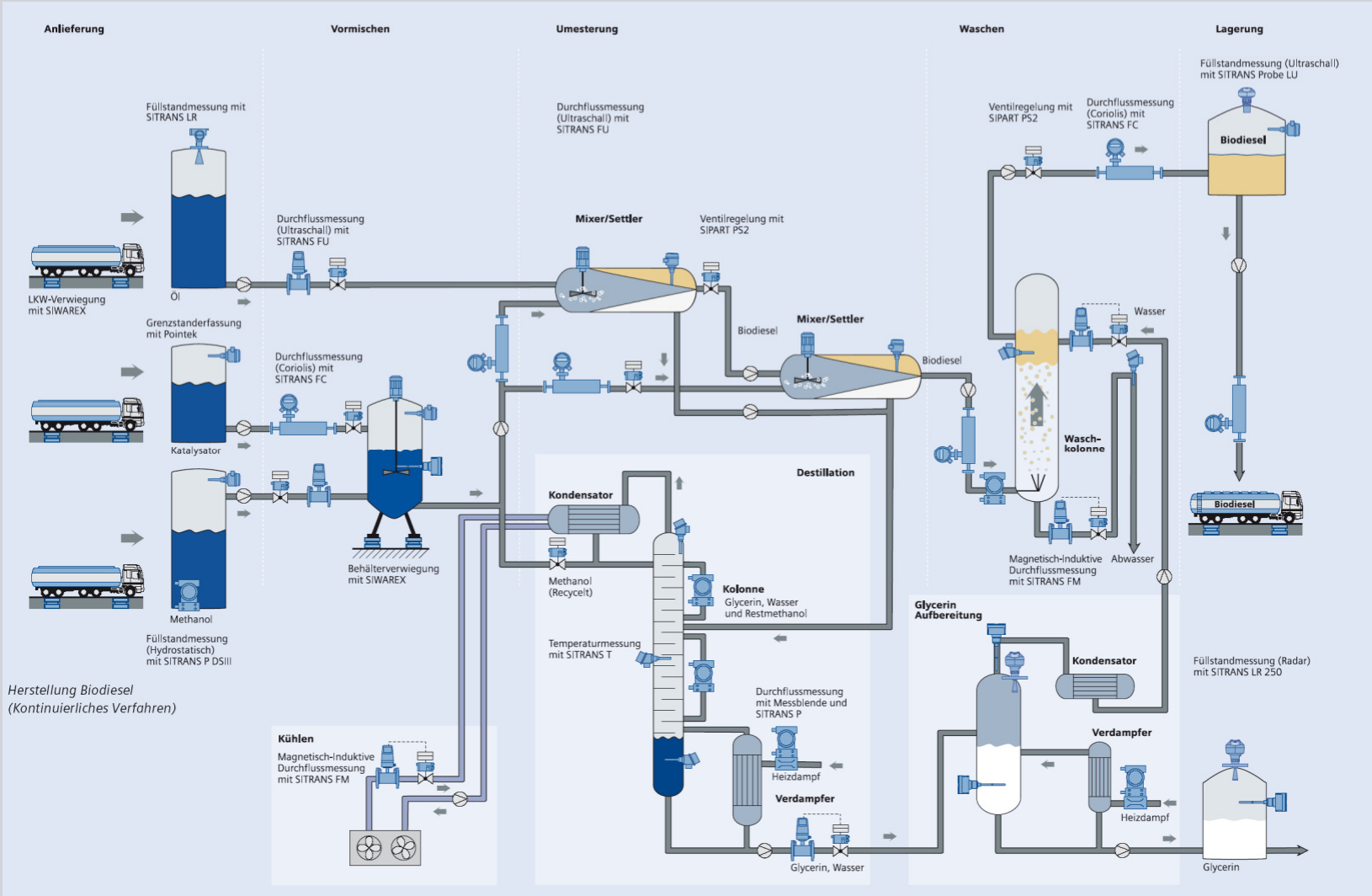

Biogas Production Process

SIEMENS

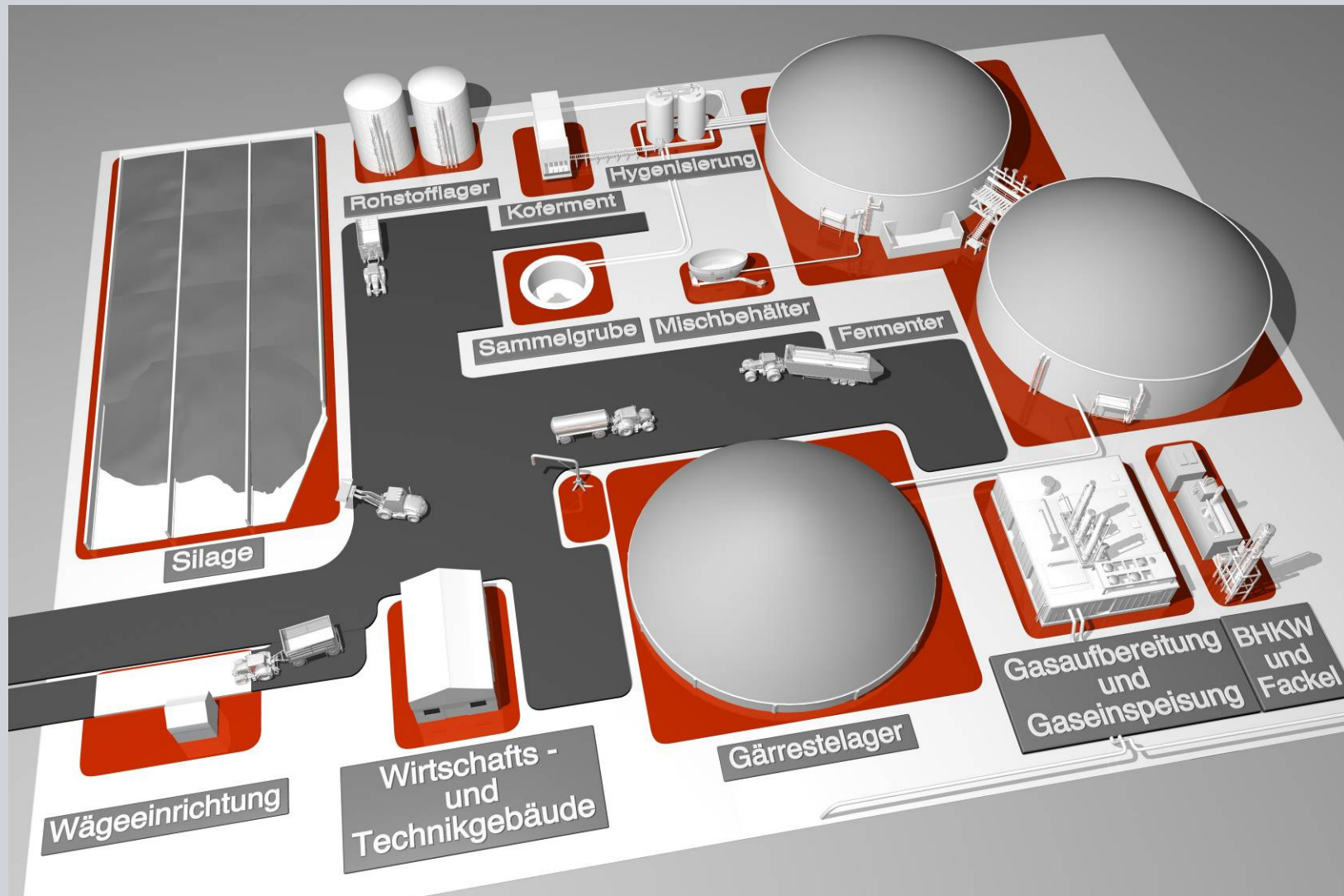

Flow Chart Biogas

SIEMENS

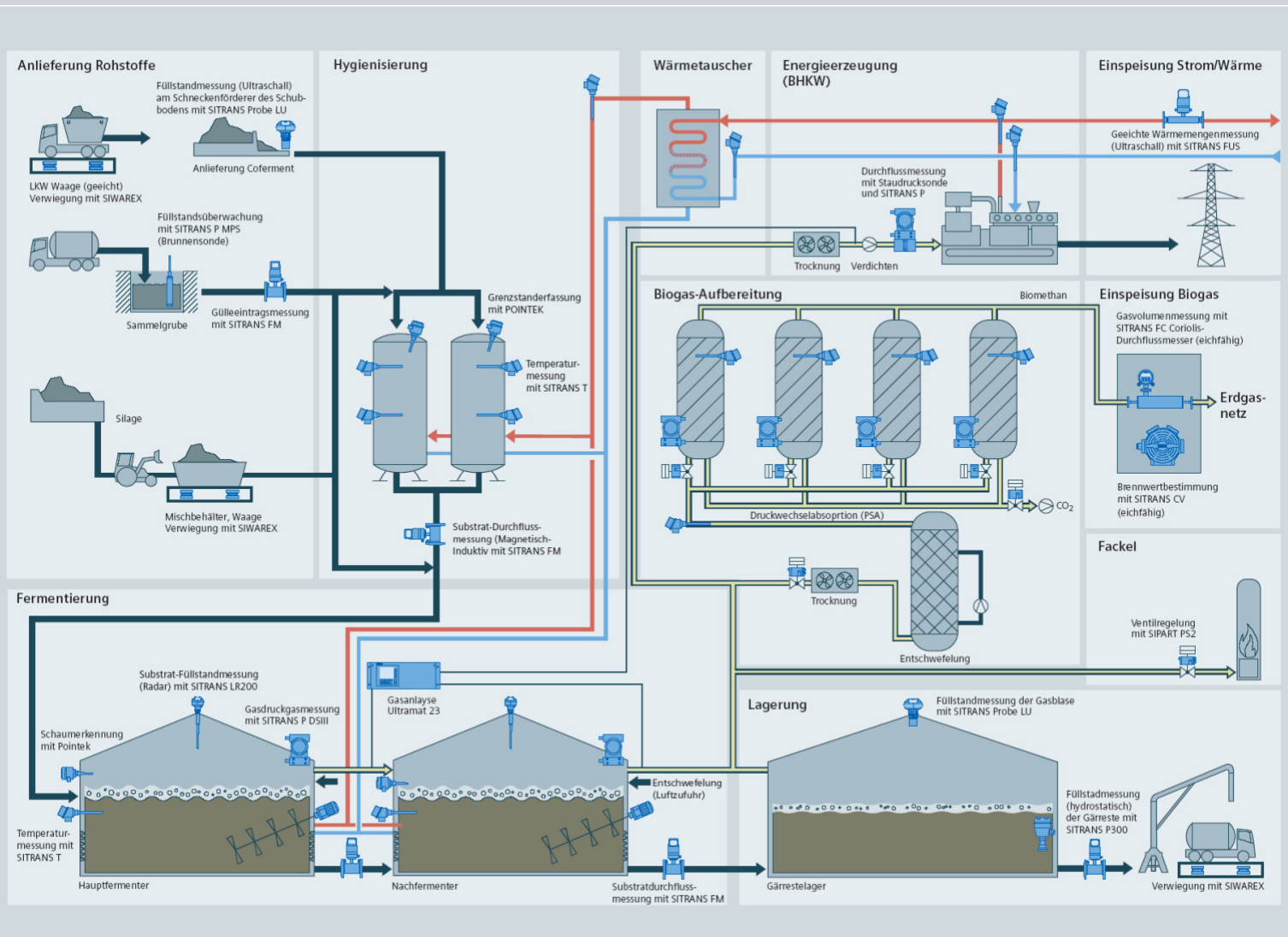

Industry Segment Solar









Opportunities in Solar Industry

SIEMENS

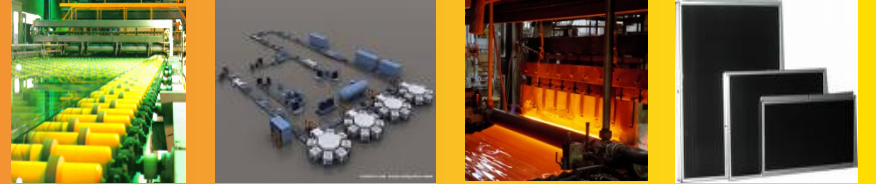

Rechte vorbehalten.

Value Chain Solar Industry

	Feed Stock	Products for Energy Conversion	Field Installation
PV Cell based	<p>MG silicon</p> <p>Poly Silicon TCS synthesis CVD reactor</p> 	<p>Ingot Brick</p> <p>Wafer mono, poly</p> <p>Cell mono, poly</p> <p>Glass assembly</p> <p>Module assembly</p> 	<p>On grid power farm</p>  <p>On grid roof top</p> 
PV Thin film	<p>Amorphous Silicon, compound Semi materials, float/cast glass</p> 	<p>Metallization of float glass</p> <p>Thin Film coating</p> <p>Tempering of glass</p> <p>Module assembly</p> 	<p>Off grid installation</p> 
CSP	<p>Glass substrate float</p> 	<p>Bending</p> <p>Mirror coating</p> <p>Glass tube receiver</p> 	<p>On grid power farm</p> 

PV = Photo Voltaic, CSP = Concentrated Solar Power

**Connectivity with emphasis on Wireless Solutions
Alcohol,Solvents,Lubricants**

SIEMENS



Wireless Technologies, Concepts and Applications



Wireless Communication today and tomorrow

Customer requirements can be solved optimally and reliably

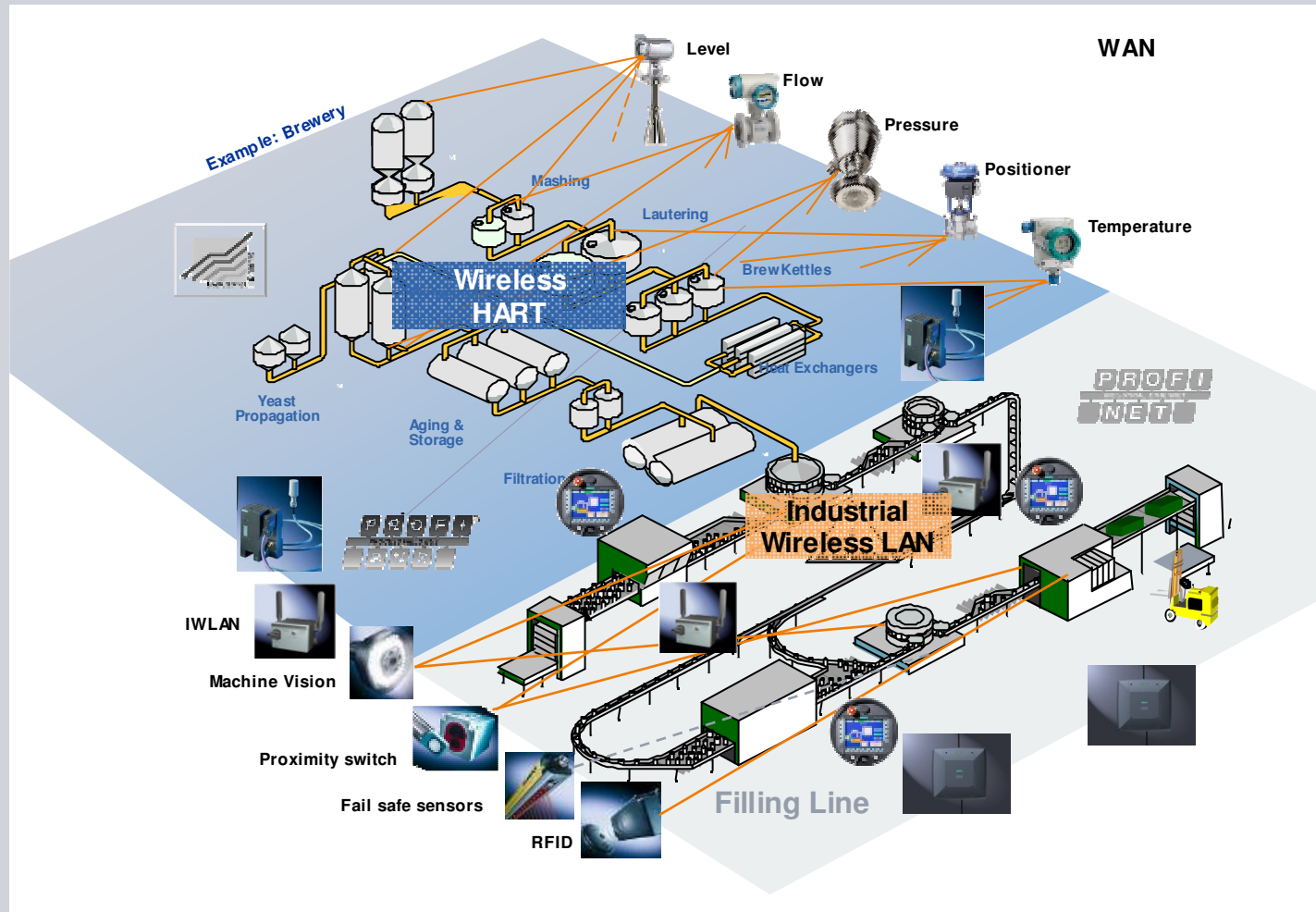

- GSM
- GPRS
- EDGE
-
- Wide Area Networks (wireless)

Wireless Sensors for Process Automation

Wireless makes stranded diagnostics data airborne

SIEMENS

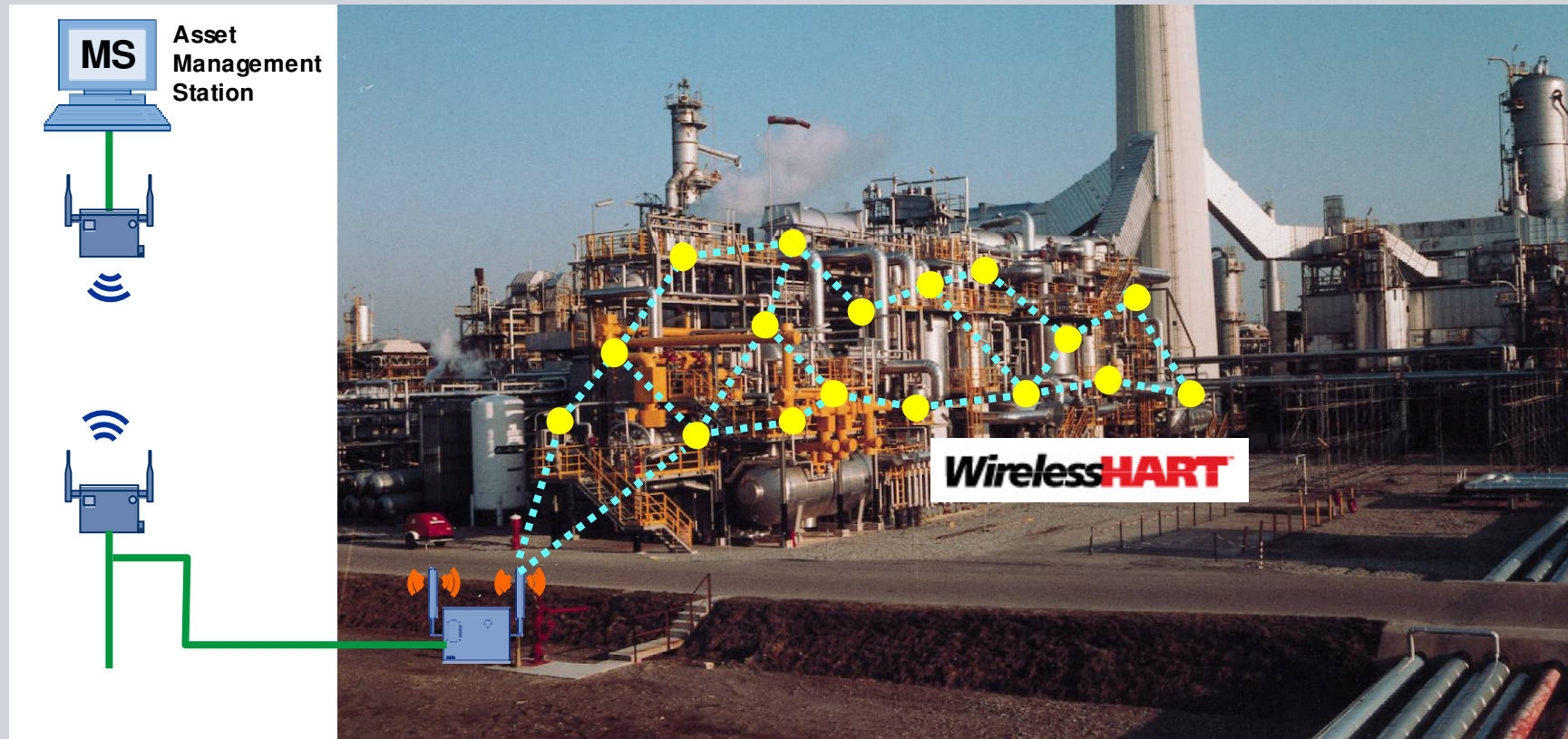

This application allows predictive maintenance and condition monitoring without impact to any installed automation system which doesn't support integrated HART communication (~90% in market)

Condition Based Monitoring / Management

The goal and target is competent support starting with the planning process of production facilities until the commissioning and start up as well as support and consultancy over the whole facility life cycle in order to reduce follow up costs as part of Total Costs of Ownership and Down Time and avoid additional unexpected modifications to optimize production volume and quality.

The key tasks for the increase of efficiency during the implementation of condition based monitoring management are:

- **Reduction of unexpected down time**
- **Production quality**
- **Production quantity**
- **Production effectivity and repeatability**
- **Protection equipment and components**
- **Increase of safety**
- **Reduction of non useful preventive maintenance**
- **Energy Efficiency**

Up to 50% of preventive maintenance investments are not necessary, these expenses can increase up to 20% of the total maintenance costs.

This conclusion is a clear statement and fact to change from preventive to predictive maintenance strategies.